

---

# Table of Contents

## Testing Cables and Breakout Boxes

Subject	Page
<b>Connectors</b> .....	<b>5</b>
Connector Contact Removal Kit .....	5
Socket and Spring Contacts .....	5
Instrument Cluster Illumination Bulb Holder Removal Socket .....	6
Relay Holder Disengaging Tool .....	6
Circular Connector Lock Disengager .....	7
BMW Plug System Abbreviations .....	7
Plug System D1.5/D2.5 .....	8
Circular Plug 7-8 Pin System D2.5 .....	8
Circular Plug 20 Pin System D2.5 .....	9
Circular Plug 4-7-10-12-25 Pin System D1.5/D2.5 .....	9
In-line Plug 15 Pin System D2.5 .....	10
In-line Plug 8-, 12 Pin System D2.5 .....	10
In-line Plug 20 Pin System D2.5 .....	11
In-line Plug 30 Pin System D2.5 .....	11
Plug System JPT/MDK/DFK .....	12
In-line plug 2 Pin System JPT ELA .....	12
In-line plug 2 Pin System MDK 3 plus 2.8 .....	12
In-line plug 4 Pin System DFK ELA .....	13
Installation Instructions .....	13
Plug System Elo/Elo-Power .....	14
In-line Plug 3-,6 Pin System Elo-Power 2.8 .....	14
In-line plug 4-,10 Pin System Elo .....	14
In-line Plug 6-,50 Pin System Elo .....	15
Plug System MQS/MPQ .....	16
In-line Plug 6-,8 Pin System MQS .....	16
In-line Plug 2 Pin System MPQ 2.8 .....	16
Control Unit Plug 25-, 35-, 55-,83-,88 Pin .....	17
In-line Plug 24 Pin Hybrid System MQS/MPQ .....	17
Socket Housing .....	17
Pin Housing .....	18
Socket Housing 42-,43 Pin Hybrid Systems MQS/MPQ .....	19
Installation Instructions .....	19
Socket Housing 2x27-, 2x27 Pin Hybrid System MQS/MPQ, Elo/Elo Power .....	19
In-line Plug 30 Pin Hybrid System MQS/MPQ .....	20
Socket Housing .....	20

<b>Subject</b>	<b>Page</b>
Pin Housing .....	.21
Socket Housing 5-, 8 Pin System MQS/MPQ .....	.21
Socket housing 5pin (Hybrid System MQS/MPQ) .....	.21
Socket Housing 8 Pin (MQS) .....	.22
Socket Housing (Radio Plug) Hybrid System MQS/MPS .....	.22
Removing MPQ Contacts from Radio Plug .....	.22
Removing MQS Contacts from Carrier .....	.23
Removing MPQ Contacts from Contact Carrier .....	.23
Miscellaneous Connectors .....	.24
Fuse Strip .....	.24
ECM Main Relay Connector .....	.24
Solderless Terminals And Connectors .....	.25
<b>Electrical Repair .....</b>	<b>.26</b>
Electrical Repair Kit IV .....	.26
Cable Stripper .....	.26
Crimping Tool .....	.26
Cable Stripping .....	.27
Crimping Tool .....	.28
Prepackaged Wiring Repair Sets .....	.30
Soldering Connections .....	.31
Soldering Preparation and Procedure .....	.31
<b>Break Out Boxes and V Cables, Tester and Adapter Sets .....</b>	<b>.32</b>
Breakout Boxes and "V" Cables .....	.32
55 pin Breakout Box P/N 81 12 9 425 091 .....	.33
83 Pin Breakout Box (Red Face) P/N 90 88 6 614 420 .....	.33
88 Pin Breakout Box (Green Face) P/N 88 88 6 614 410 .....	.33
134 Pin SKE Control Module Breakout Box Set P/N 90 88 6 121 300 .....	.34
26 Pin Breakout Box P/N 88 88 6 611 459 .....	.34
60 Pin Breakout Box P/N 90 88 6 614 390 .....	.34
"V" Cables .....	.35
Tester and Adapter Set for Relays .....	.36

**BLANK  
PAGE**

---

# Testing Cables and Breakout Boxes

**Model: All**

**Production: All**

# OBJECTIVES

After completion of this module you will be able to:

- Recognize and distinguish the various Electrical Repair Kits.
- Use the Connector Removal Kit.
- Recognize the plug configurations and disassemble them properly.
- Repair wiring harnesses and connectors.
- Choose the proper Breakout Box and “V” cable for testing.
- Use the relay testing tool.

# Connectors

## Connector Contact Removal Kit

The connector contact removal kit provides tools for the disassembly of connectors. Proper use of these tools enable the technician to access wiring connectors for repairs equal to factory quality.

Always refer to the latest Service Information Bulletins (Group 04) for up to date information regarding new tools.

The Connector Contact Removal Kit is used for:

- Releasing round plug housings.
- Pressing out contacts.
- Pulling out indicator lamps.
- Releasing relay carriers.

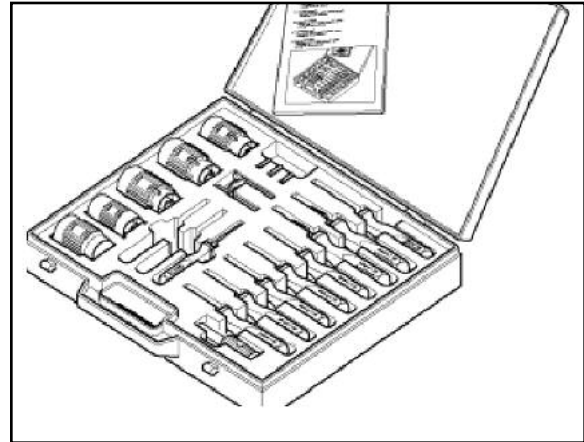

**Current P/N 88 88 6 611 150**

## Socket and Spring Contacts

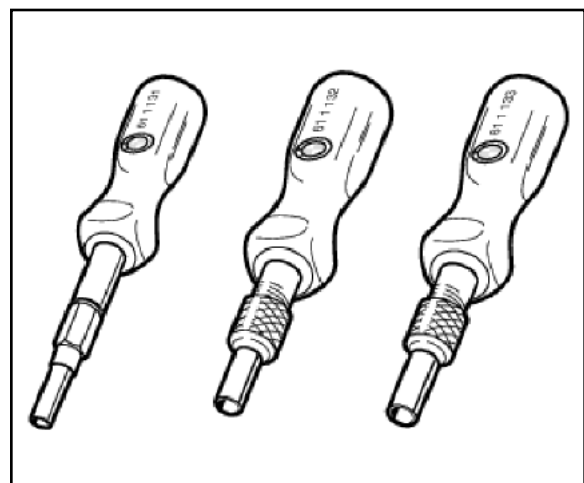
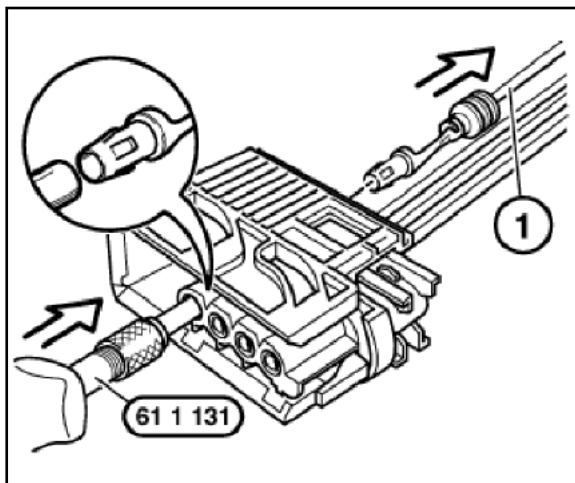

Socket and Spring contacts compress the springs while the connector is pushed from the housing.

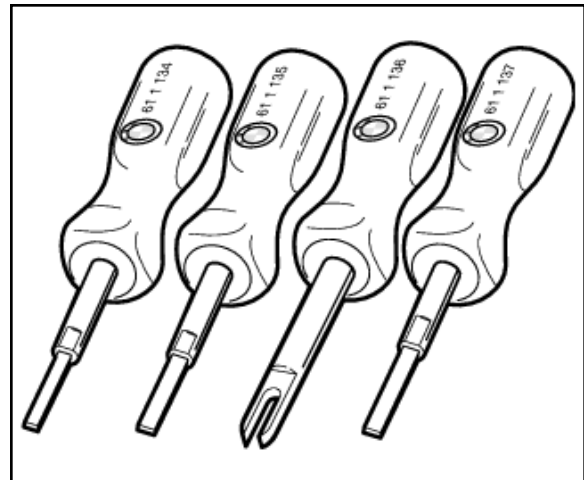
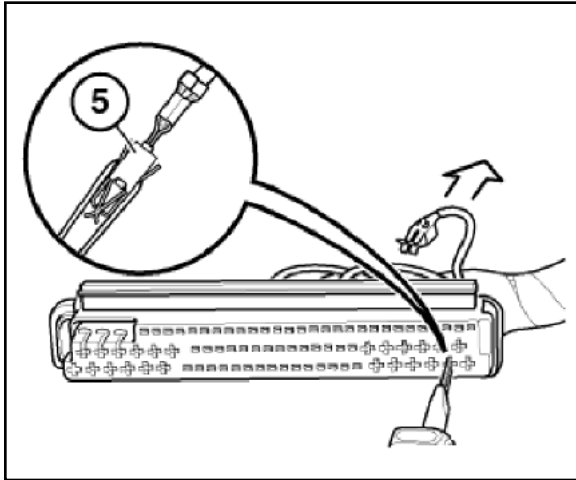

Flat spring contacts depress the spring allowing the connector to be pushed or gently pulled from the connector housing.

### Instrument Cluster Illumination Bulb Holder Removal Socket

The backlighting illumination bulbs are removed from the cluster by placing square head of the socket on the bulb holder and turning 90° counter clockwise.

The bulb removal socket is used on all instrument clusters.

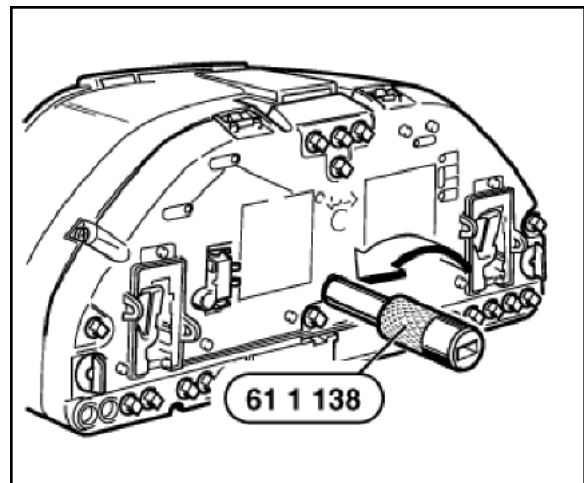

### Relay Holder Disengaging Tool

This tool allows the relay holder (2) to disengage the relay connector (1).

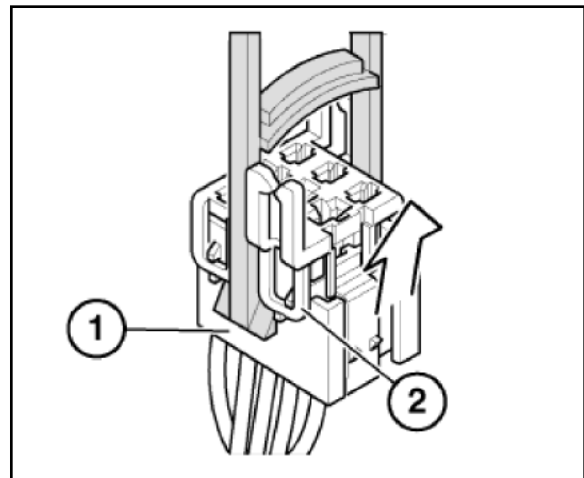

## Circular Connector Lock Disengager

These tools unlock the circular connector housings allowing the individual connectors to be removed.

The various sizes are reflected in the part numbers:

4 pin = 61 1 141

7 pin = 61 1 142

10 pin = 61 1 145

12 pin = 61 1 143

25 Pin = 61 1 144

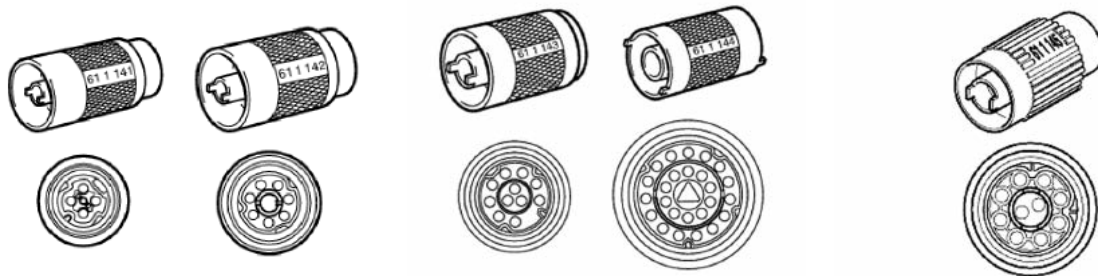
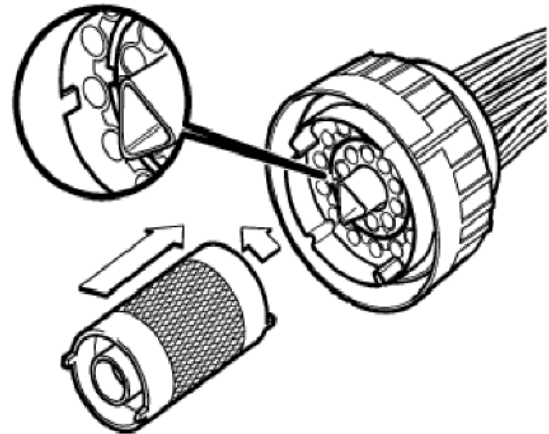

## BMW Plug System Abbreviations

D 1.5/2.5	Round contacts of 1.5mm or 2.5mm diameter
MDK 3 Plus	Miniature double flat spring contact
JPT ELA	Junior Power Timer flat spring contacts with strand sealing
DFK ELA	Double flat spring contacts with strand sealing
Elo	Electronic contacts with and without strand sealing Manufacturer: Siemens
Elo Power	Electronic contacts for heavy loads with and without strand sealing Manufacturer: Siemens
MQS	Micro Quadlock System electronic contacts with and without strand sealing Manufacturer: AMP
MPQ	Micro Power Quadlock electronic contacts for heavy loads with and without strand sealing Manufacturer: AMP

## Plug System D1.5/D2.5

### Circular Plug 7-8 Pin System D2.5

- Pull off the rubber boot (1).
- Push the retaining lugs (2) of the inner connector section 3 inward carefully to disengage the lock notch.
- Push the inner connector section (3) in the direction of the arrow in the illustration until the retaining lugs (2) are in the recessed notch (4) and use the appropriate sized spring contact tool and remove the connector from the housing.

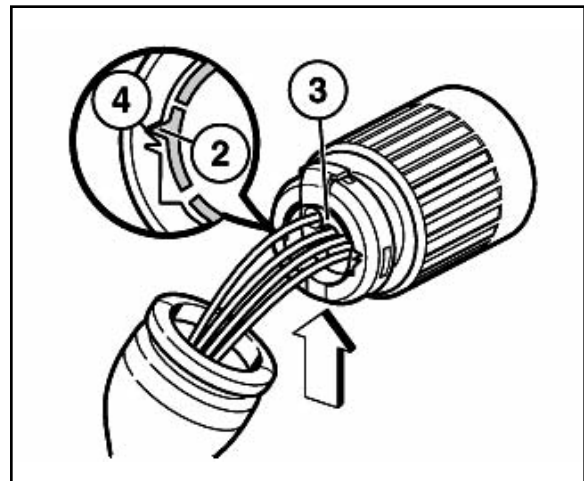
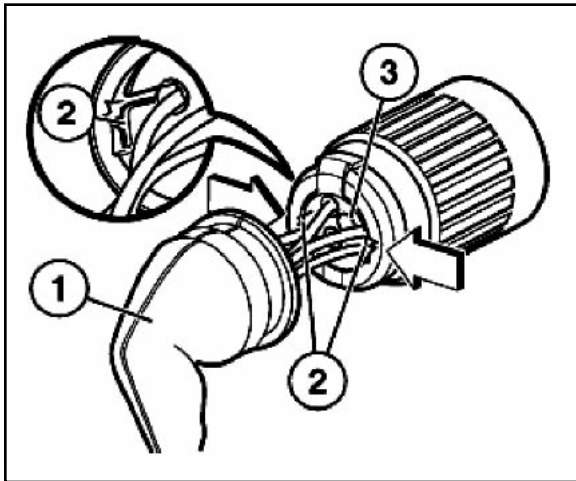

### Circular plug 13 Pin System D2.5

- Carefully pull off the rubber grommet (1).
- Pull the lock retainers (2) outward (direction of arrows) to allow the lock notch to disengage.
- Pull the inner section (3) upward as shown in the illustration until the lock notches (4) are in the released position of the lock retainers (5) and use the appropriate size spring contact and remove the connector from the housing.

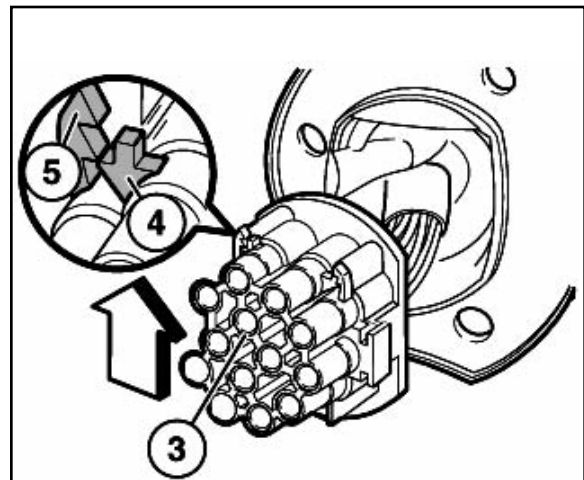
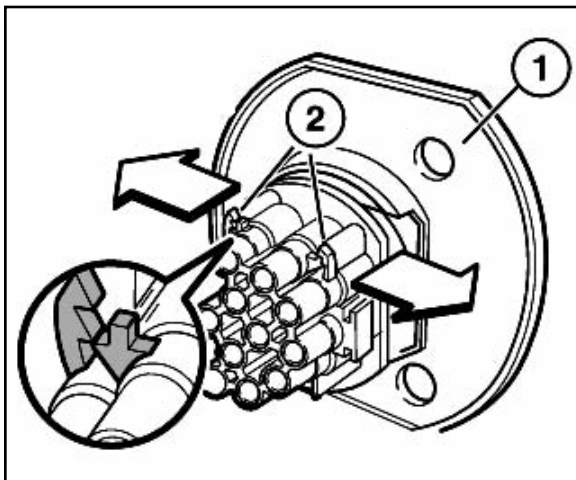



## Circular Plug 20 Pin System D2.5

- With the boot pulled back, press the lock tabs (1) of the inner connector section (2) inward.
- Simultaneously, rotate the inner connection section (2) counter clockwise to allow the lock tabs (1) to engage in the unlocked position and use the appropriate sized spring contact and remove connector from the housing.

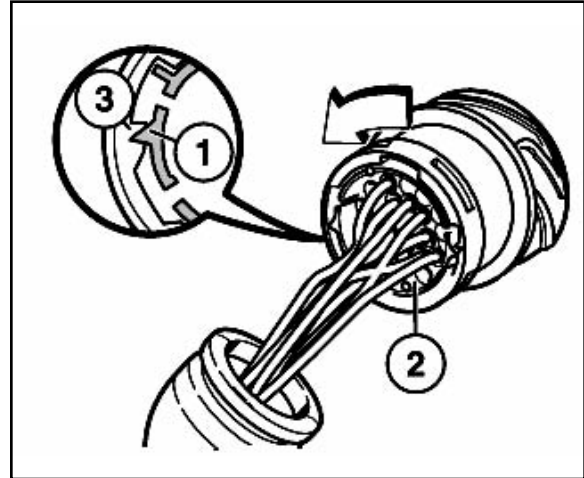
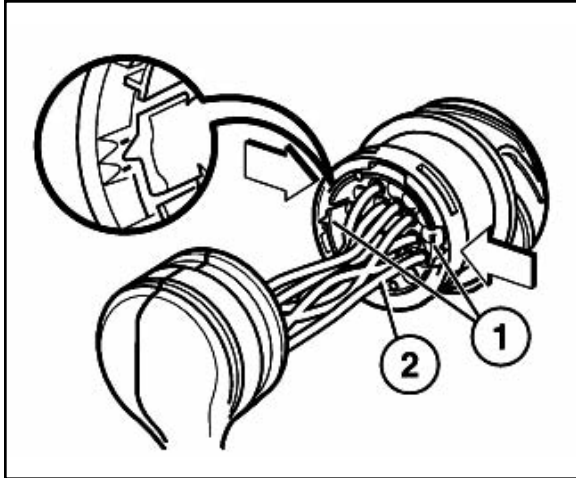

## Circular Plug 4-7-10-12-25 Pin System D1.5/D2.5

- Insert the appropriate unlocking tool (determined by the number of pins) into the connector.
- The connector is unlocked when the lock tab (3) is in the unlocked position (1). The connector is locked when the lock tab (3) is in the locked position (2).
- Use the appropriate sized spring contact and remove connector from the housing.

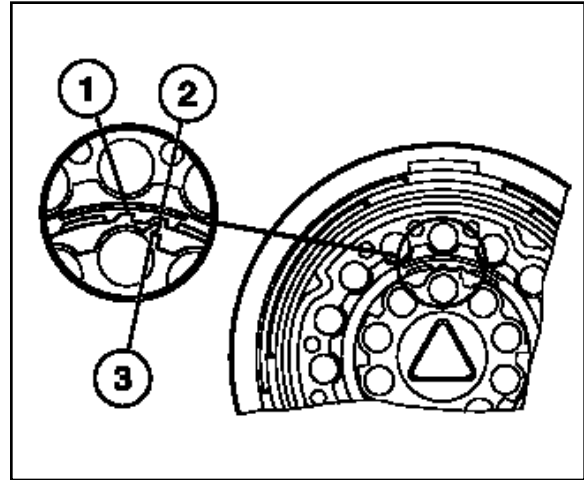
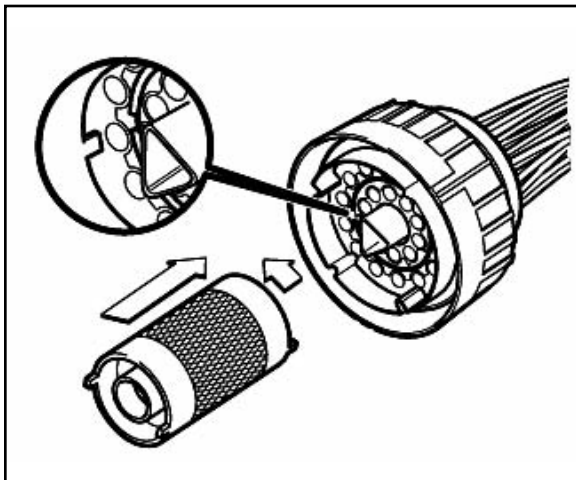

## In-line Plug 15 Pin System D2.5

- Pull the outer connector section (1) slightly outward in the area of lock tabs (2).
- Simultaneously, slide the inner connector section (3) in the direction of the arrow to the unlocked position.
- Use the appropriate sized spring contact and remove connector from housing.

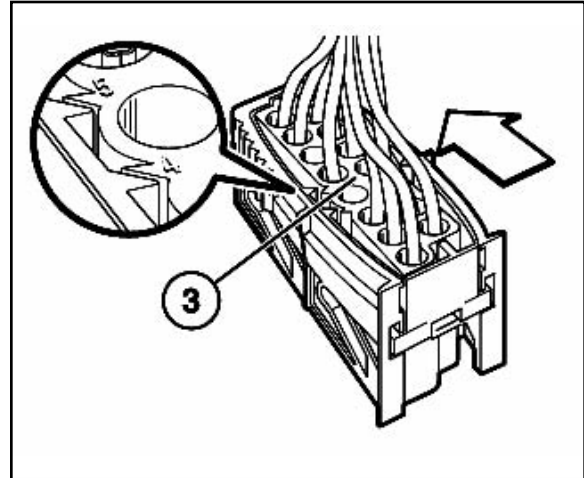
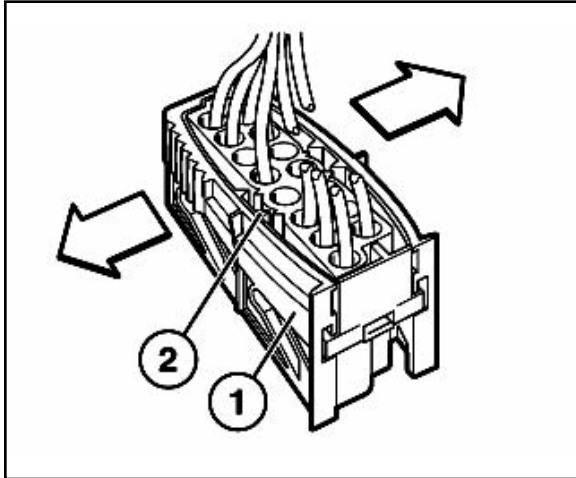

## In-line Plug 8-, 12 Pin System D2.5

- Slide the upper section (1) and the lower section (2) of the connector in opposite directions to unlock the connector.
- Using special tool **61 1 132** press the spring latch down and pull the connector (3) from the housing.

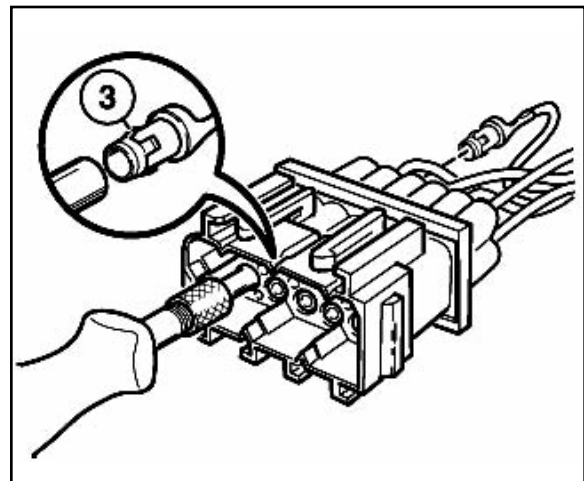
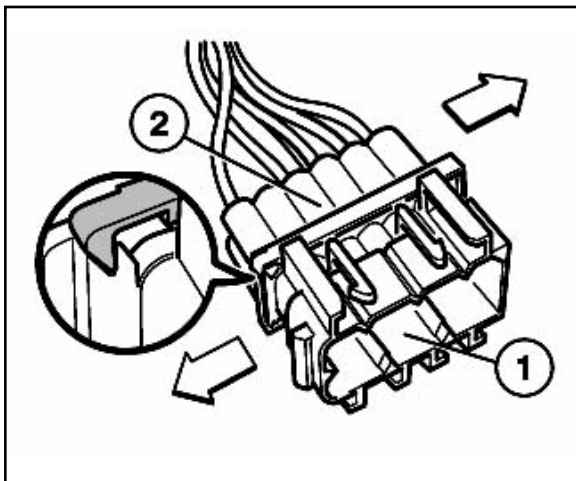

### In-line Plug 20 Pin System D2.5

- Pull locking slide (1) completely out of connector (2).
- Using special tool **61 1 132** press the spring latch down and pull the connector from the housing.

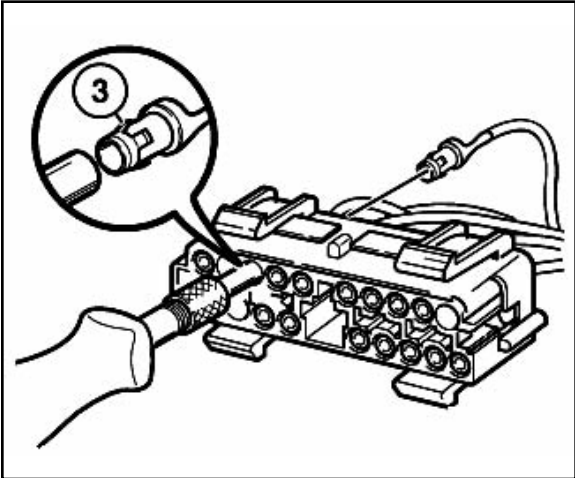
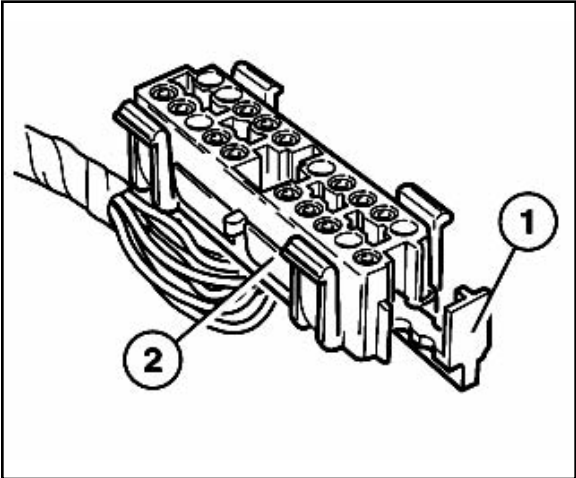

### In-line Plug 30 Pin System D2.5

- Pull the outer section (1) slightly outward in the area of lock tabs (2).
- Simultaneously, slide the inner connector section (3) in the direction of the arrow to the unlocked position.
- Use the appropriate sized spring contact and remove connector from housing.

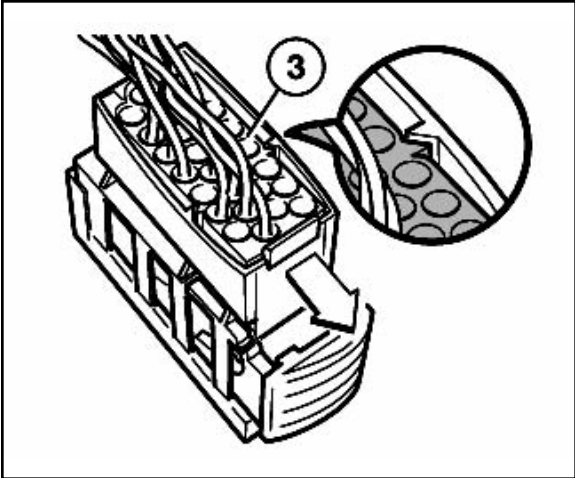
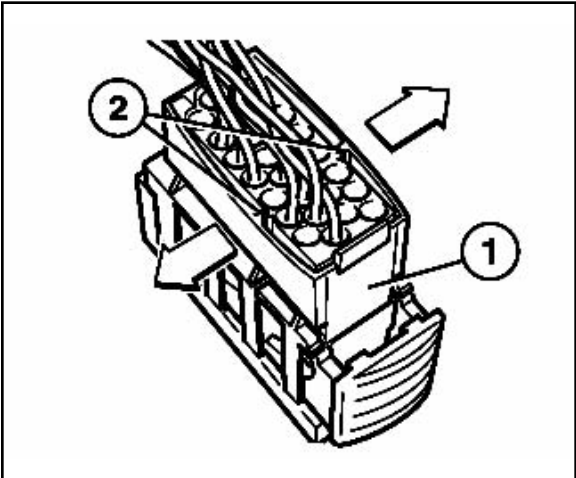

## Plug System JPT/MDK/DFK

### In-line plug 2 Pin System JPT ELA

- Press lock (1) in direction of arrow and slide plug forward.
- Press lock (1) downward and slide out to one side.
- Unlock contact with special tool **61 1 136** and pull out cable (2) and contact towards rear.

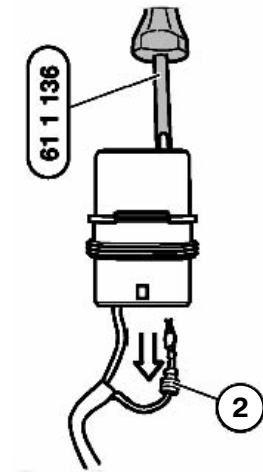
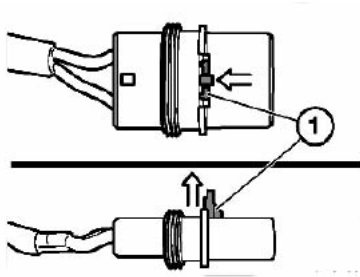
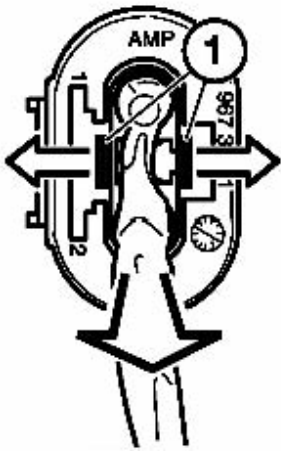

### In-line plug 2 Pin System MDK 3 plus 2.8

- Unlock lock (1) on outside at arrester hook and slide out lock (1) side.
- Unlock contact with special tool **61 1 136** and pull out cable (2) and contact towards rear.

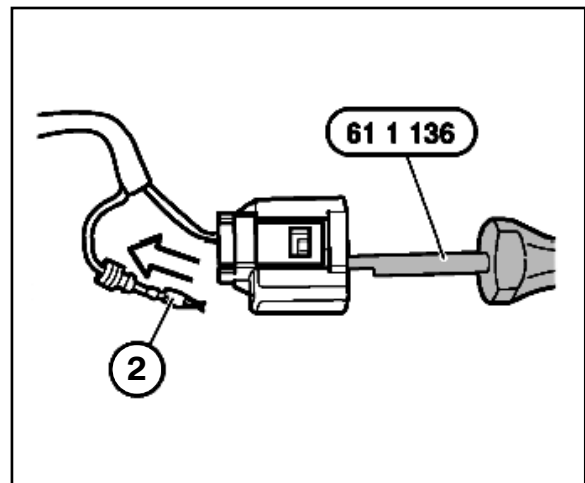
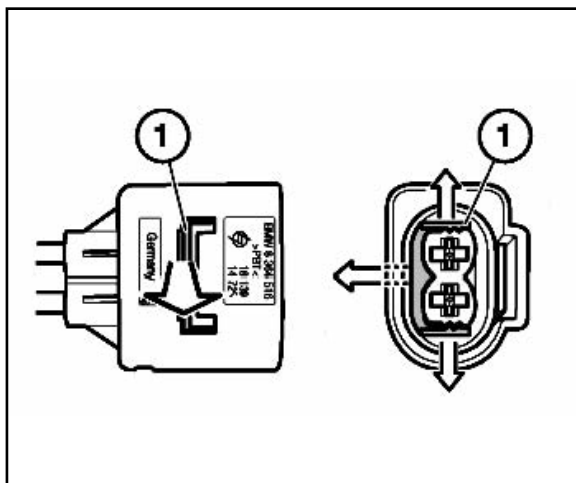

## In-line plug 4 Pin System DFK ELA

- Press arrester hook in direction of arrow and remove lock (1).
- Unlock contact with special tool **61 1 136** and pull cable and contact out towards rear.

### ■ Installation Instructions

- If necessary, slide lock must also be unlocked with screw driver.

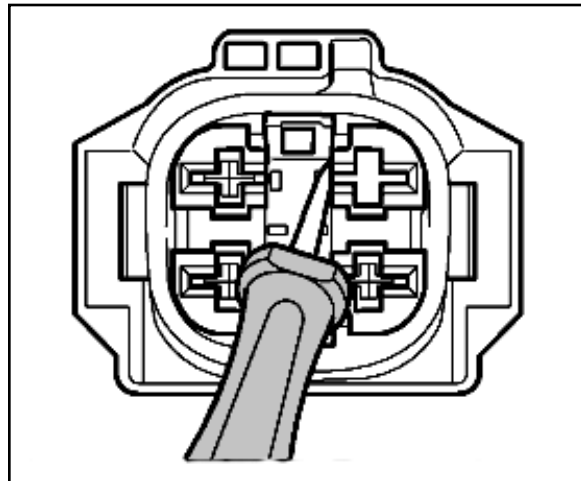
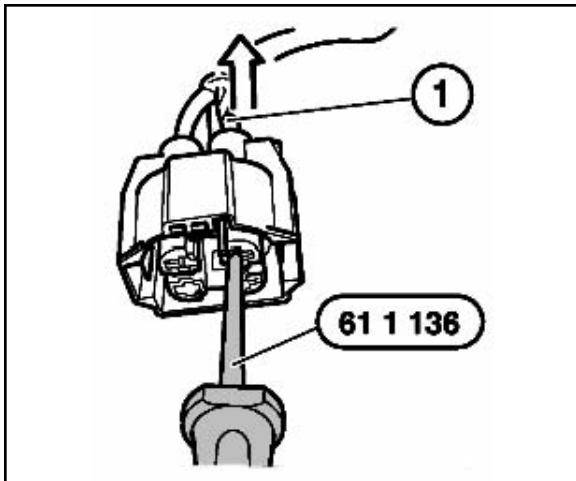
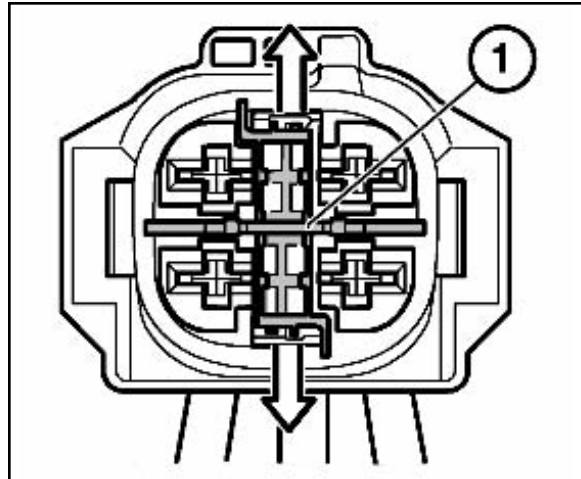

### Notes:

---

---

---

---

---

---

---

---

---

---

---

---

## Plug System Elo/Elo-Power

### In-line Plug 3-,6 Pin System Elo-Power 2.8

- Press unlocking hook (1) in direction of arrow and disengage. Then unlock locking hook (2) and remove lock.
- Press down arrestor hook (3) with screwdriver and pull out cable with contact towards rear.

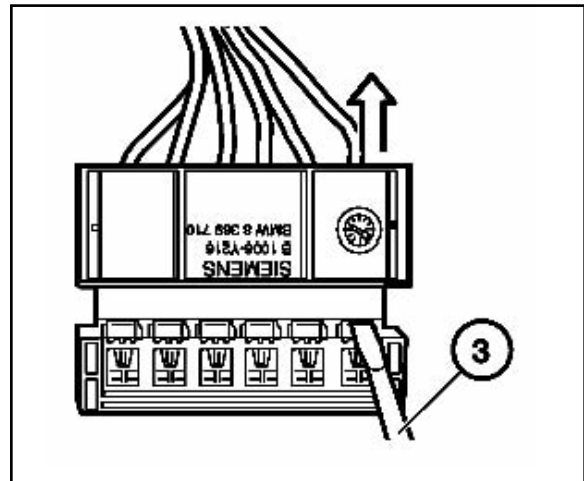
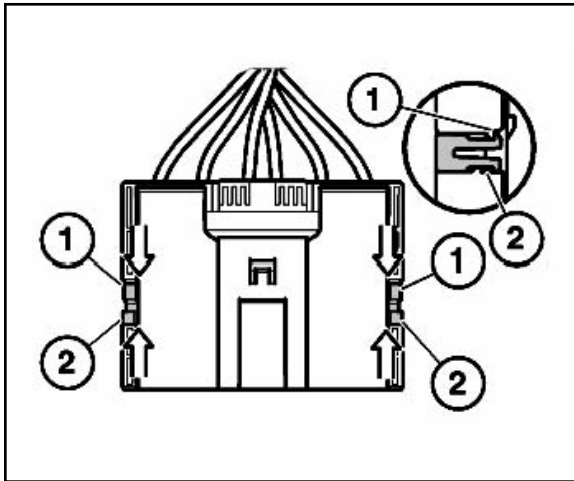

### In-line plug 4-,10 Pin System Elo

- Slide connector lock (1) off of main connector body.
- Push the lock tab of the connector being removed down (3) with pin or small screwdriver in the primary lock slot(4) and pull the wire out (5) to the secondary lock position (6).
- Push the lock tab down again in the secondary lock position and remove wire completely.

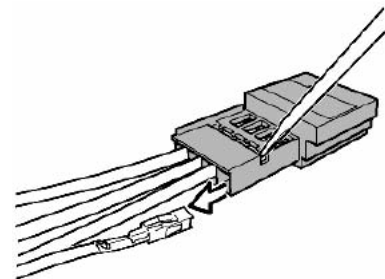
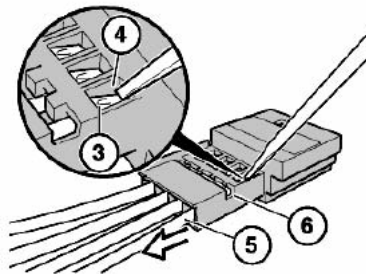
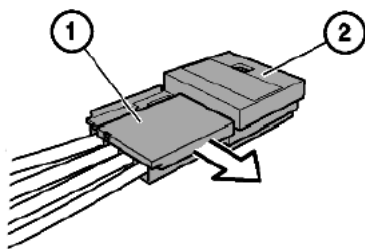

## In-line Plug 6-,50 Pin System Elo

- Unlock lock (Fig. 14/1).
- Unfasten cable clip (Fig. 14/2).
- Slide connector lock (1) off of main connector body (2) (Fig. 14/3).
- Push the connector plate (3) out of connector shell using a small screwdriver through hole on end of connector body (Fig. 14/4).
- Push the lock tab of the connector being removed down (6) with pin or small screw driver in the primary lock slot (7) and pull the wire out to the secondary lock position (8) (Fig. 14/5).
- Push the lock tab down again in the secondary lock position and remove wire completely (Fig. 14/6).

Fig. 14/1

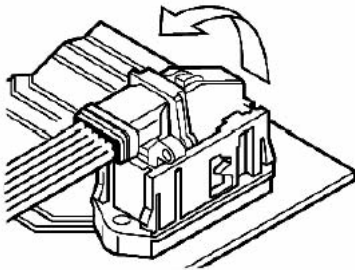

Fig. 14/2

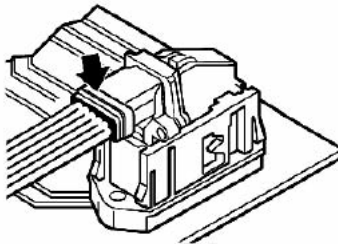

Fig. 14/3

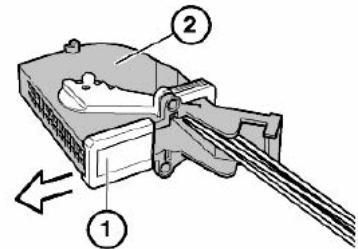

Fig. 14/4

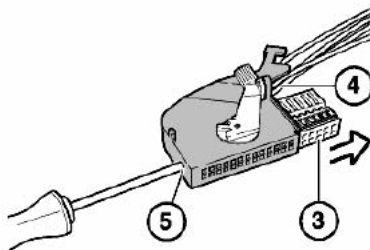

Fig. 14/5

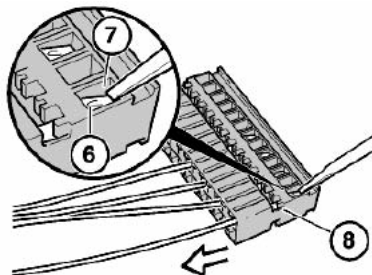
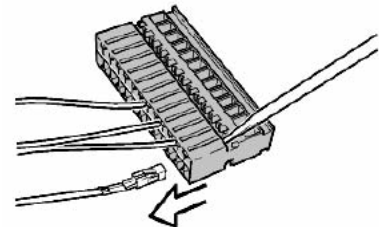

Fig. 14/6



## Plug System MQS/MPQ

### In-line Plug 6-,8 Pin System MQS

- Press lock (1) in direction of arrow and slide plug forward.
- Press locking hook (2) downward and slide lock (1) out.
- Press down arrester hook (3) with screwdriver and pull out cable with contact towards rear.

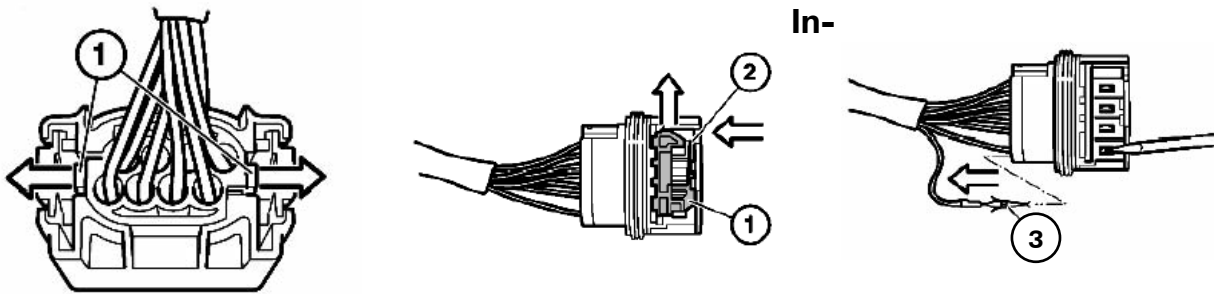

### line Plug 2 Pin System MPQ 2.8

- Press catch on outside in direction of arrow and remove towards top.
- Press down arrester hook (1) with screwdriver and pull out cable and contact (2) towards rear.

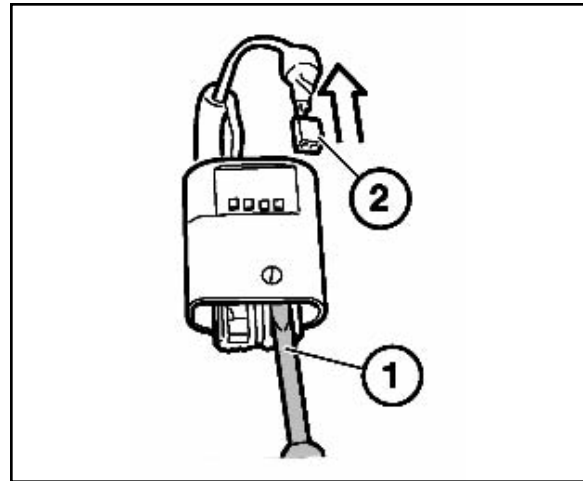
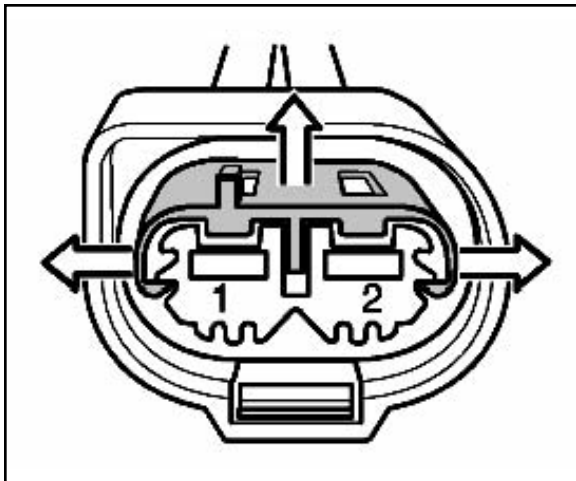



## Control Unit Plug 25-, 35-, 55-,83-,88 Pin

- Remove phillips head screws (1) from connector. Gently pivot the connector plate (2) with seal (3) out of the connector shell.
- Remove seal (3) and pull connector plate lock (4) out of locked position.
- Using the appropriate sized spring contact and remove connector (5) from housing.

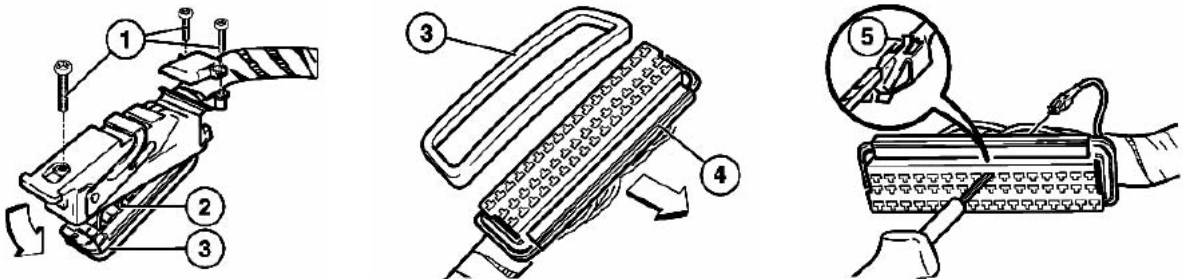

## In-line Plug 24 Pin Hybrid System MQS/MPQ

**Manufactured by AMP:** The following contact types without strand sealing can be fitted in the plug housings:

- MQS (Micro Quadlock System)
- MPQ, width 2.8 mm (Micro Power Quadlock)
- MPQ, width 5.2 mm (Micro Power Quadlock)

### ■ Socket Housing

- Press locks (1) on cap (2) upwards on both sides.
- Detach cap from contact carrier (3).

**Note: Detaching the cap releases the secondary lock of the socket contacts.**

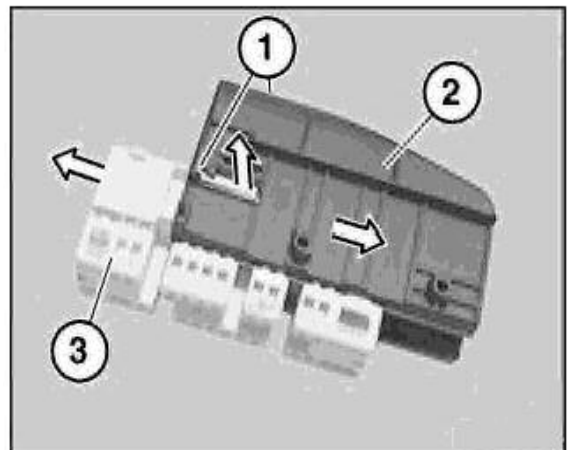

- Hold down retaining hook (1) of socket contact carrier with a small screwdriver.
- Pull wire with socket contact in direction of arrow as far as secondary lock (2). (Fig. 17/1)
- Hold down retaining hook in secondary lock (1) again and pull cable with socket contact (2) completely out of contact carrier (3). (Fig. 17/2)

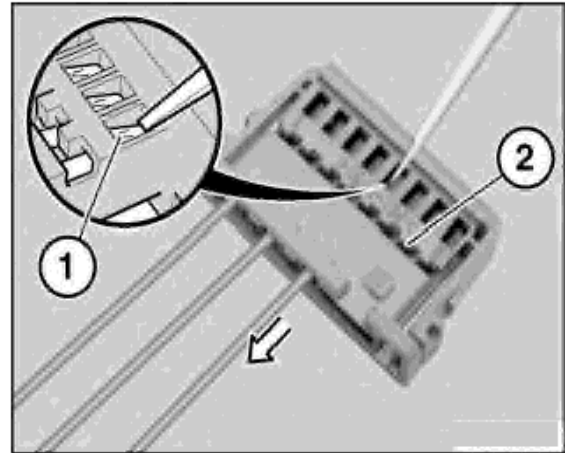

Fig. 17/1

### Pin Housing

- Press locks (1) on cap (2) upwards on both sides.
- Detach cap from housing carrier (3) (Fig. 17/3).

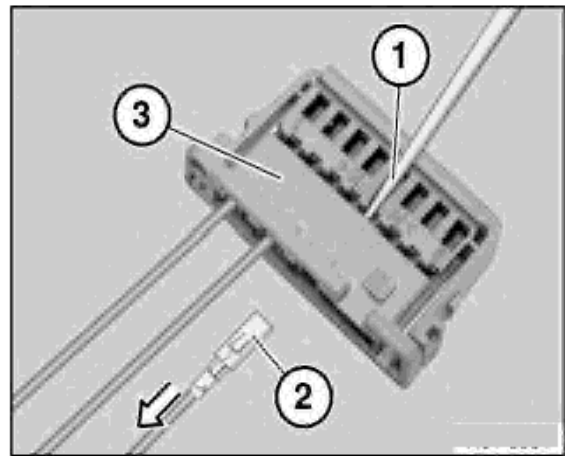

Fig. 17/2

**Note: Detaching the cap releases the secondary locks of the pin contacts in the contact carriers.**

- Pull contact carrier (1) out of housing carrier (2) (Fig. 17/4).
- The pin contacts are pulled of a contact carrier as described under “Socket Housing”.

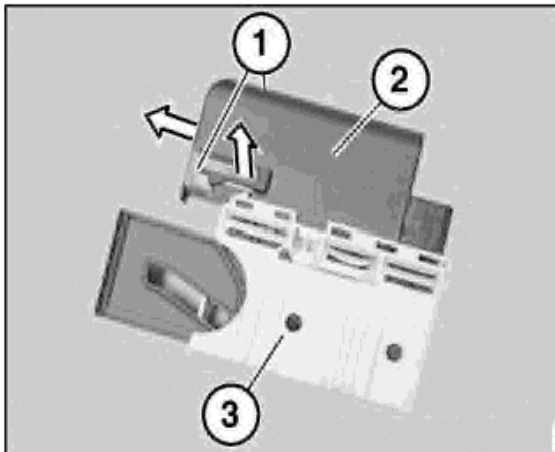

Fig. 17/3

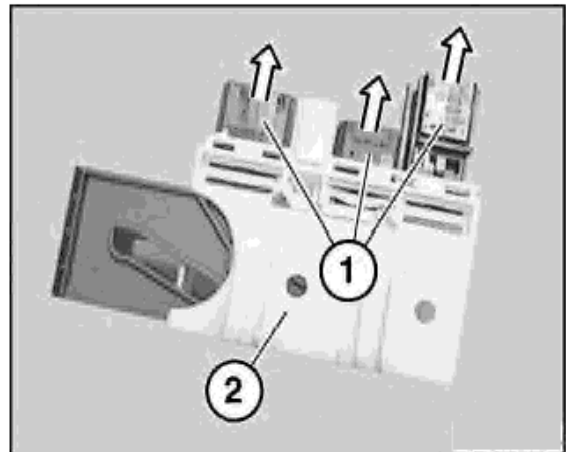

Fig. 17/4

## Socket Housing 42-,43 Pin Hybrid Systems MQS/MPQ

**Manufactured by AMP:** The following contact types without strand sealing can be fitted in the socket housings:

- MQS (Micro Quadlock System)
- MPQ, width 2.8 mm (Micro Power Quadlock)
- MPQ, width 5.2mm (Micro Power Quadlock)

- Open secondary locks (1) on socket housing.
- Press back retaining hook of **MQS** contacts (2) with special tool **61 1 134** and pull out cable with contact.
- Press back retaining hook of **MPQ** contacts (3) with screwdriver or similar tool and pull out cable with contact.

### ■ Installation Instructions

- Bend open retaining hook of contacts gently before inserting into plug housing.
- To install contacts, observe cavity numbers on reverse side of socket housing.

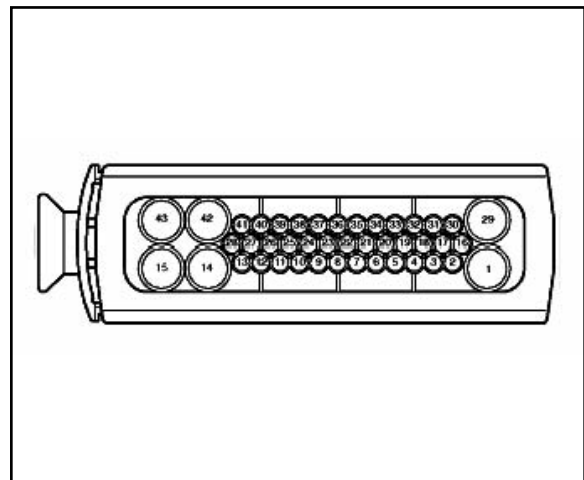
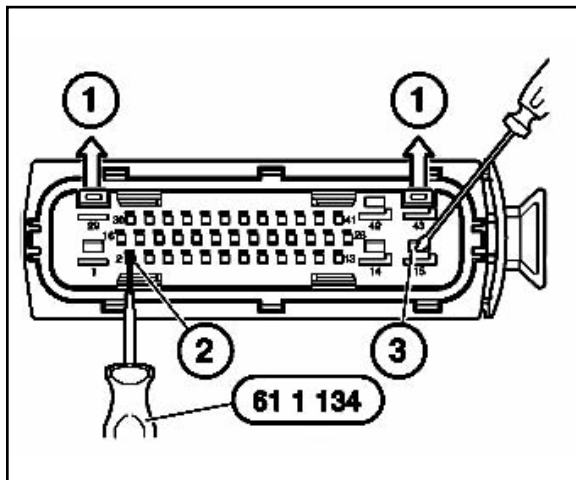

## Socket Housing 2x27-, 2x27 Pin Hybrid System MQS/MPQ, Elo/Elo Power

**Manufactured by Amp:** The following contact types without strand sealing can be fitted in the socket housings:

- MQS (Micro Quadlock System)
- MQS, width 2.8 mm (Micro Power Quadlock)
- MPQ, width 5.2 mm (Micro Power Quadlock)

**Manufactured by Siemens:** The following contact types without strand sealing can be fitted in the socket housings:

Elo (electronic contact)

Elo-Power 2.8 mm wide (electronic contact for heavy loads)

Elo-Power 5.2 mm wide (electronic contact for heavy loads)

- Raise lock (1) on housing (2).
- Push contact carrier (3) from rear out of housing.

**Note: The second carrier is pushed out in the same way. Pushing out the contact carrier releases the secondary locks of the secondary contacts.**

Procedure for removing contacts are same as for other Elo/Elo-Power Systems, refer to those instructions.

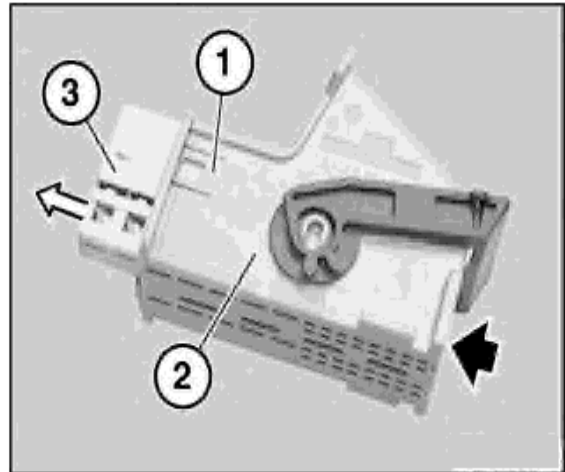

### In-line Plug 30 Pin Hybrid System MQS/MPQ

**Manufactured by AMP:** The following contact types without strand sealing can be fitted in the plug housings:

MQS (Micro Quadlock System)

MPQ, width 2.8 mm (Micro Power Quadlock)

MPQ, width 5.2 mm (Micro Power Quadlock)

#### ■ Socket Housing

- Raise lock (1) on housing (2).
- Push contact carrier (3) from rear out of housing (2).

**Note: Pushing out the contact carrier releases the secondary locks of the socket contacts.**

Procedure for removing contacts are same as for other Elo/Elo-Power Systems, refer to those instructions.

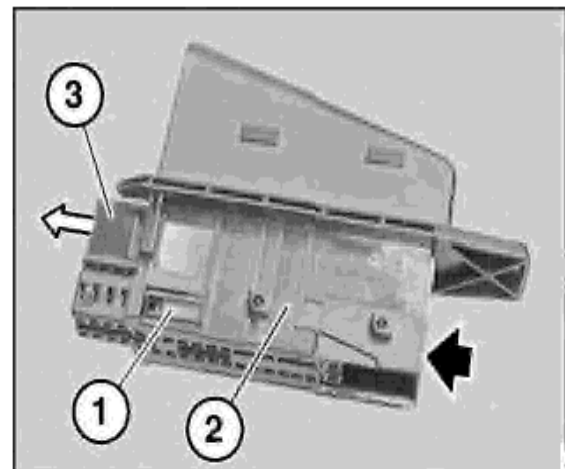

## Pin Housing

- Contact 1...13 and 19...27.
- Raise locking slide(1) on both sides (2) of housing and detach.

**Note: Detaching the locking slide releases the secondary locks of the pin contacts.**

- Contacts 14...18 and 28...30.
- Pull slide (1) outward completely.
- Raise lock (2) on housing.
- Pull contact carrier out of housing.

**Note: Pulling out the contact carrier releases the secondary locks of the pin contacts.**

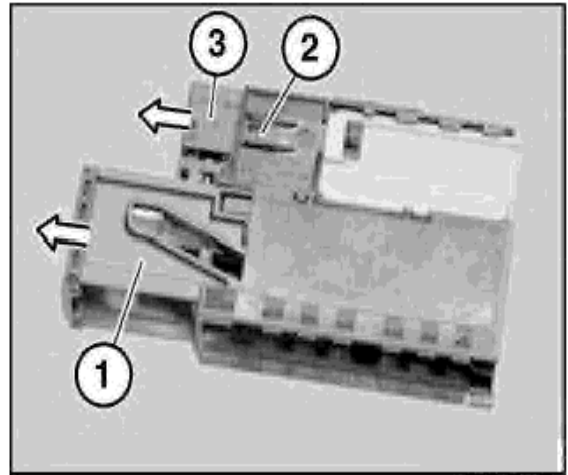
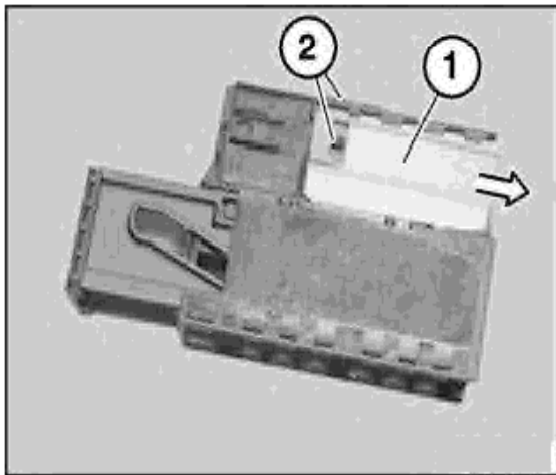

## Socket Housing 5-, 8 Pin System MQS/MPQ

**Manufactured by AMP:** The following contact types without strand sealing can be fitted in the socket housings:

MQS (Micro Quadlock System)

MPQ, width 2.8 mm (Micro Power Quadlock)

MPQ, width 5.2mm (Micro Power Quadlock)

## Socket housing 5pin (Hybrid System MQS/MPQ)

- Raise fastener (1) (slide) by way of retaining lug (2) and detach from contact carrier (3).

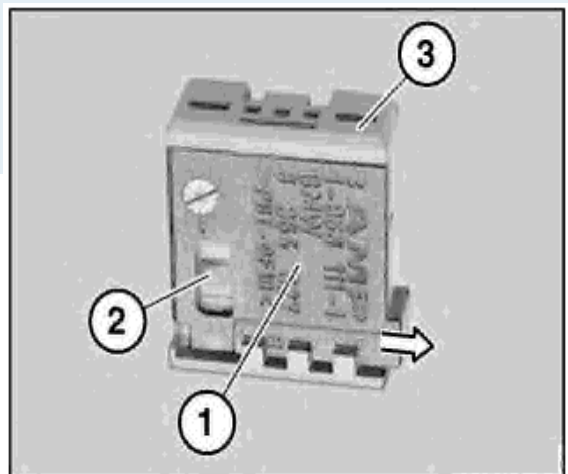

## Socket Housing 8 Pin (MQS)

- Raise fastener (1) (slide) by way of retaining lug (2) and detach from contact carrier (3).

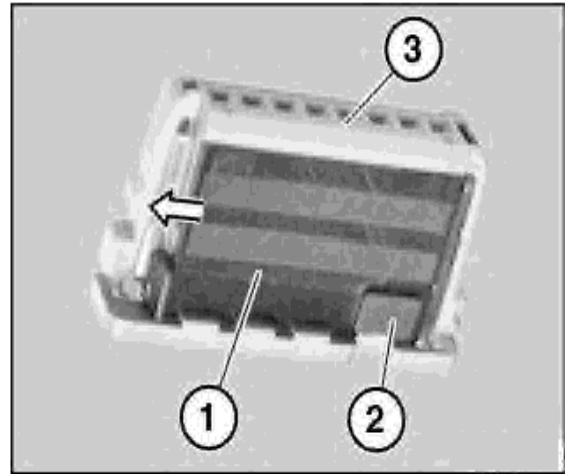

Procedure for removing contacts are same as for other Elo/Elo-Power Systems, refer to those instructions.

## Socket Housing (Radio Plug) Hybrid System MQS/MPS

**Manufactured by AMP:** The following contact types without strand sealing can be fitted in the plug housings:

- MQS (Micro Quadlock System)
- MPQ, width 2.8 mm (Micro Power Quadlock)
- MPQ, width 5.2 mm (Micro Power Quadlock)

## Removing MPQ Contacts from Radio Plug

- Press lock (1) in direction of arrow, detach secondary lock (2) from radio plug.
- Feed special tool 61 1 135 past side of contact.
- Press special tool 61 1 135 in direction of arrow.
- Pull wire (1) with socket contact out of radio plug(2).

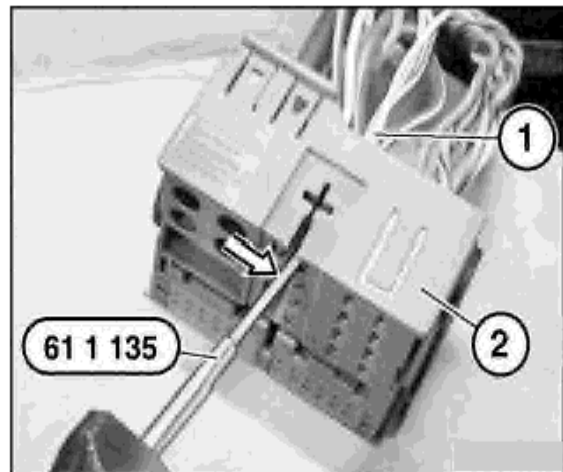
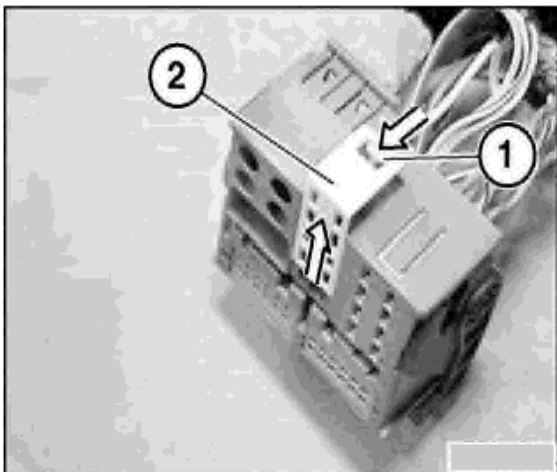



## Removing MQS Contacts from Carrier

- Press lock (1) in direction of arrow and pull housing (2) out of radio plug (Fig. 22/1).
- Press lock (1) in direction of arrow. Pull contact carrier (2) out of housing (Fig. 22/2).

**Note: When the contact carrier is pulled out, the secondary locks of the socket contacts are raised.**

Procedure for removing contacts are same as for other Elo/Elo-Power Systems, refer to those instructions.

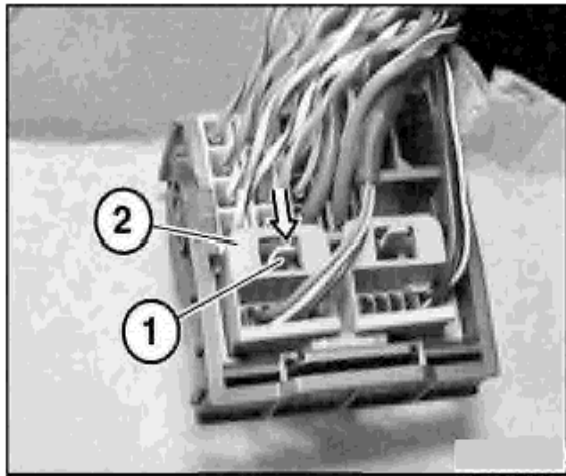

Fig. 22/1

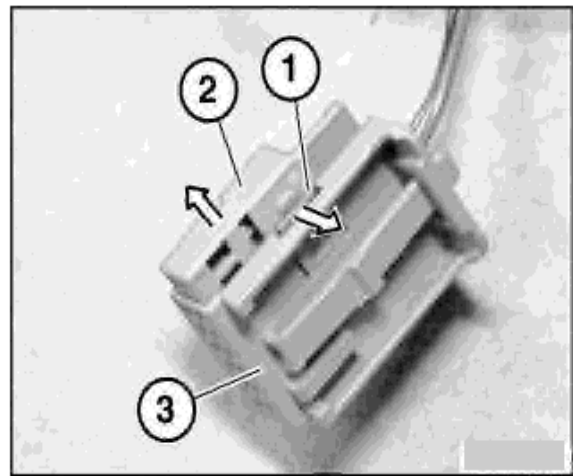

Fig. 22/2

## Removing MPQ Contacts from Contact Carrier

- Remove contact carrier (1) with MQS contacts from radio plug. Raise lock (2) on radio plug. Pull contact carrier (3) out of radio plug (Fig. 22/3).
- Press lock (1) in direction of arrow. Pull secondary lock (2) in direction of arrow completely out of contact carrier (3) (Fig. 22/4).
- Press special tool 61 1 135 on inside of contact into contact carrier(2). Pull wire with socket contact (1) out of contact carrier (2) (Fig. 22/5).

Fig. 22/3

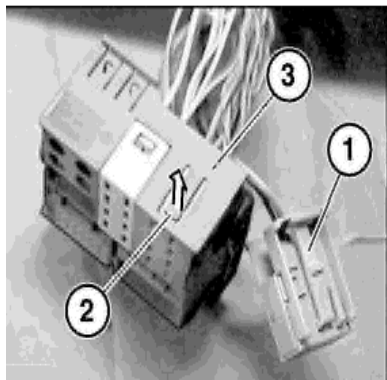

Fig. 22/4

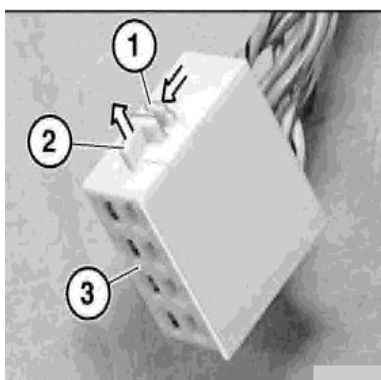
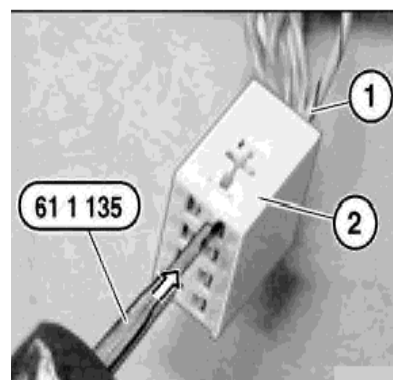

Fig. 22/5



## Miscellaneous Connectors

### Fuse Strip

- Pull appropriate fuse from fuse strip (1).

**Note: Mark fuse rating and position for reinstallation.**

- Pull locking slide (2) out of fuse strip until stop is felt.
- Using special tool **61 1 136** or **61 1 1**

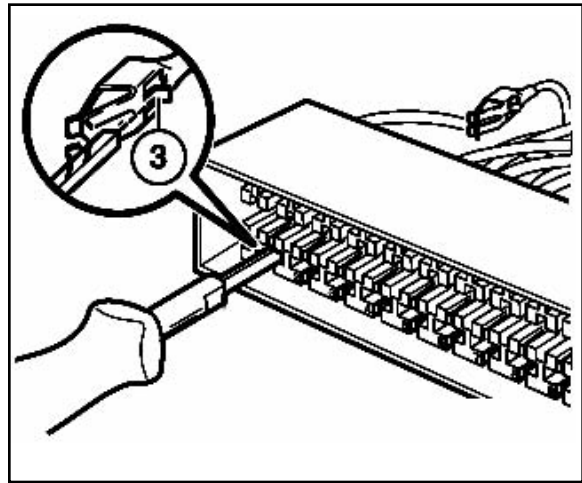
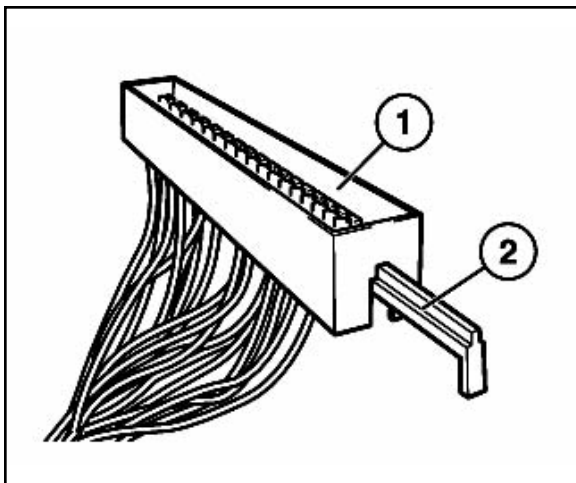

### ECM Main Relay Connector

- Unlock wire flap (1) of connector being removed.
- Using special tool **61 1 136** or **61 1 137** press the spring latch down (2) and pull the connector from the housing.37 press the spring latch down (3) and pull the connector from the housing.

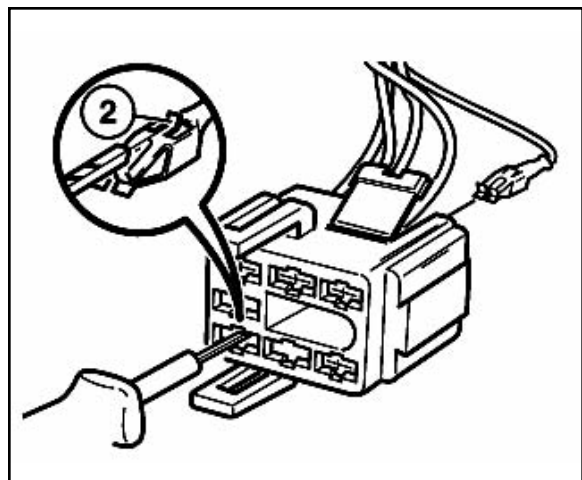
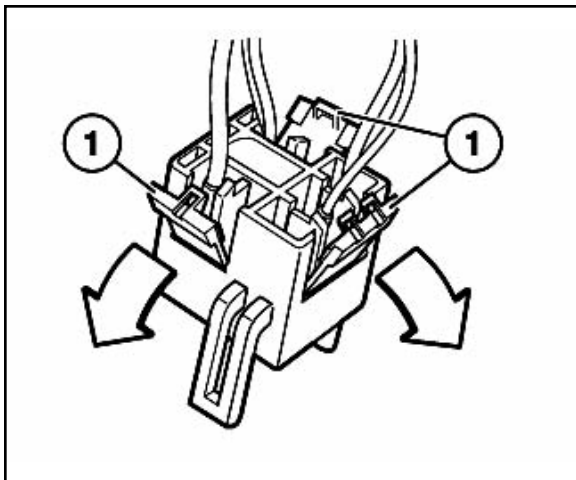



---

## Solderless Terminals And Connectors

Mechanical strength of solderless terminal design and electrical conductivity must be maintained at all times. To ensure these characteristics are maintained in the vehicles electrical system several BMW repair kits are available.

The repair kits listed contain all the approved connectors, pins, and tools required for proper repair of BMW's electrical, electronics components.

- **Electrical Repair Kit IV**

P/N 90 88 6 619 020

The Electrical Repair Kit IV (Ref. SI. 04 18 92) is used in conjunction with the instruction manuals and detailed repair manual procedures **from Group 61, Sub-group 13** found in TIS.

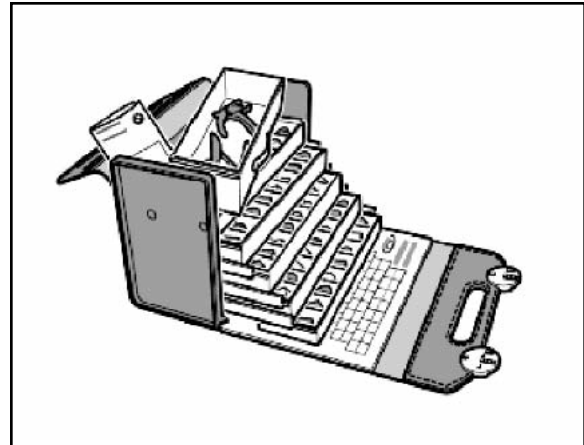

These procedures include:

- Disassembling, replacing a plug connection on the various types of connectors.
- Cutting cable to length.
- Crimping stop parts (Contacts).
- Butt connectors for repairing a plug connection.

Operating instructions for special tools and the handling of individual parts in the repair kit are available under **PN 61 9 029**.

Three previous kits issued by BMW are:

- **Electrical Repair Kit I** (Black Case)

P/N 81 24 9 408 080

- **Electrical Repair Kit II** (Blue Case)

P/N 81 24 9 408 300

- **Electrical Repair Kit III** (Red Case)

P/N 82 11 9 408 400



Electrical repair kits I, II and III are primarily needed for repairing wiring harness and connectors of older vehicles (E30 and earlier). Refer to repair kit instructions, SI bulletins and repair manual microfiche. Operating instructions for special tools in these kits are available under **PN 61 8 084**.

# Electrical Repair

## Electrical Repair Kit IV

The Electrical Repair Kits (I,II,III and IV) have gone through various upgrades.

Electrical Repair Kit IV (PN 90 88 619 020) has been developed to handle repairs of the specialized state of the art wiring and harnesses of the newest BMW products.

### Caution:

The special tools contained in the Electrical Repair Kits I,II,III are not state of the art and are not suitable for specialized wiring harness repairs.

Use exclusively Electrical Repair Kit IV for those repairs.

### Electrical Repair Kit IV (61 9 020)

Contains the following:  
61 9 041 Crimping Tool  
61 9 042 Matrix  
61 9 043 Cable Stripper  
61 9 044 Matrix  
Assorted Individual Parts

### Cable Stripper

Special Tool **61 9 043** Cable stripper with wire cutter for cutting and stripping insulation from cables.

### Crimping Tool

Special Tool **61 9 041** Crimping Tool with special tool **61 9 044** (matrix) for crimping cable guide and strain relief device on antenna elbow plug.

Supplementary kits for Electrical Repair Kit IV are released periodically. Check the latest Service Bulletin to insure information on latest connectors are available.

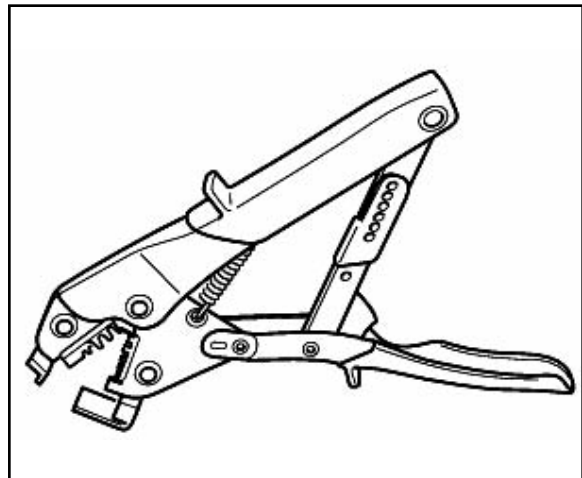
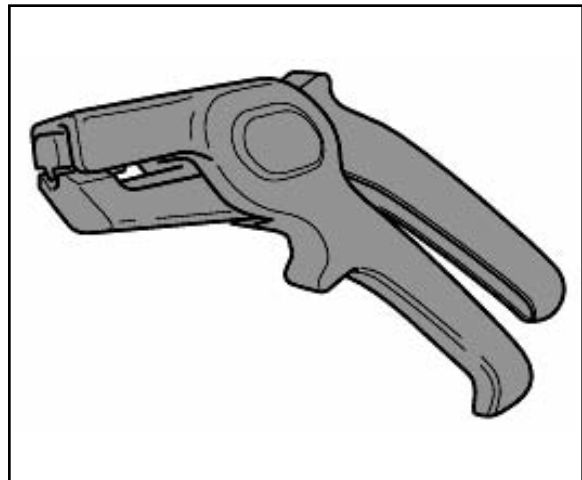
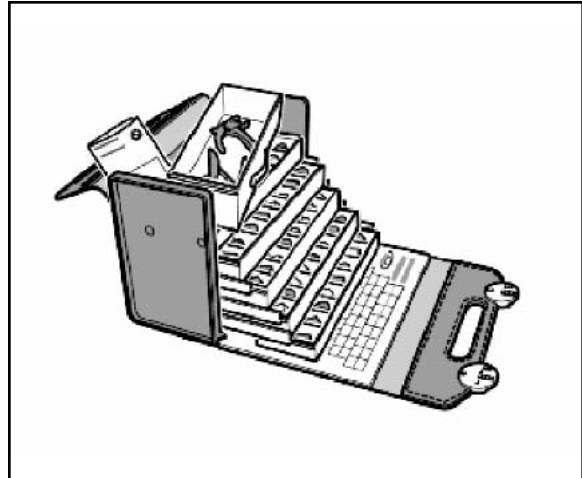

## Cable Stripping

Proper wire stripping and connector replacement is essential to ensure the integrity of the electrical connection. Always follow specific instructions in the Electrical Repair Kit IV instruction manual as well as Group 61 - 13 repair manual found in the TIS.

The length of wire to be stripped is determined by the wire gauge.

Wire cross-section size	Stripped length:
mm <sup>2</sup>	mm
0.35 ... 0.50	4.0
0.75 ... 1.00	4.5
1.00 ... 2.50	5.0

Proper use of the wire stripping tool will provide consistently positive results. Insert the wire (1) into the stripper. Stop the wire when the required strip length is past the cutter (2). Squeeze the handle of the tool.

When the top jaw of the tool touches the wire (3) the mechanism shifts the clamping action to a pulling action which strips the wire of the insulation (4).

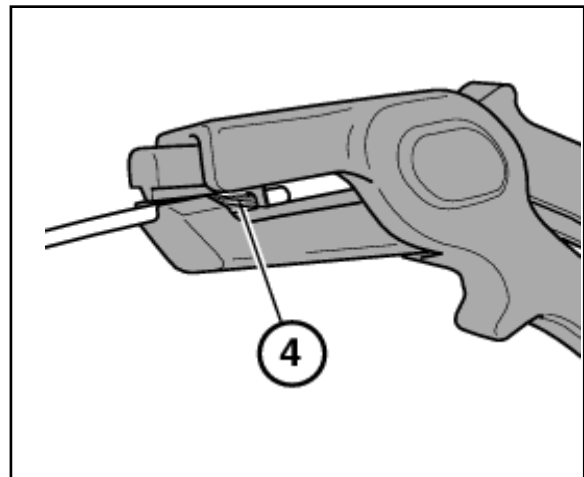
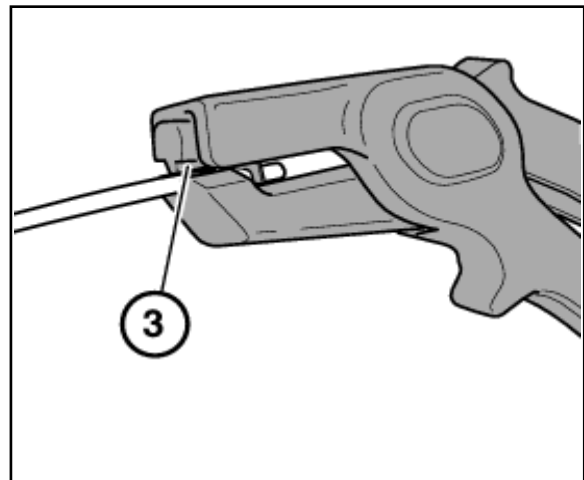
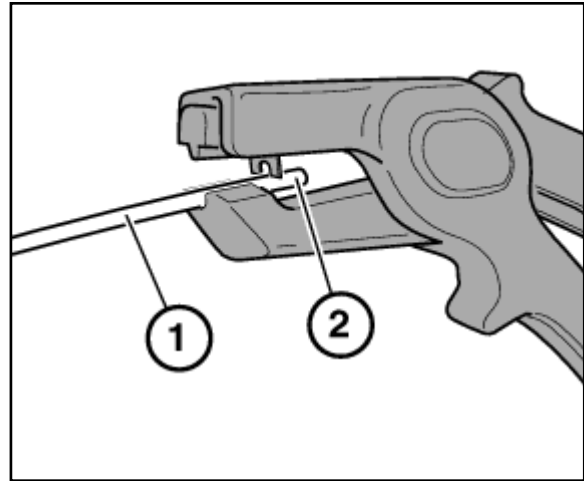

## Crimping Tool

Use the wire crimper from the BMW Electrical Repair Kit. This crimper is designed for the specific connectors found in BMW automobiles. Proper use of the tools will provide consistent good quality connector crimps.

The crimper is designed to apply just the right amount of pressure based on the wire gauge and connector size.

The tool has removable crimper jaws (3). This feature allows for an unlimited number of connector types for future compatibility. The repair manual refers to the different sized crimping slots as “Nests”. The gauge of the wire being crimped determines which “Nest” is used.

Nest	Wire cross-section size
1	0.35 ... 0.50mm <sup>2</sup>
2	0.75 ... 1.00mm <sup>2</sup>
3	1.50mm <sup>2</sup>
4	2.50mm <sup>2</sup>

### Example:

A .75 - 1.0mm gauge wire requires nest 2 for proper crimping.

Throughout the Electrical Repair Kit instruction manual are illustrations of various connectors being crimped. The highlighted box of the 16 box grid in these illustrations refers to the storage compartment in the electrical kit drawers in which that specific connector can be found.

Insert the “crimping end” of the connector into the appropriate “nest”. Illustration provides example of comb replacement connector (4) and inline splice connector (5).

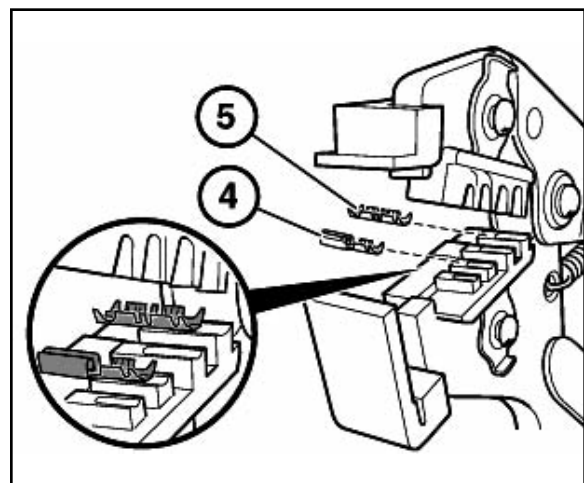
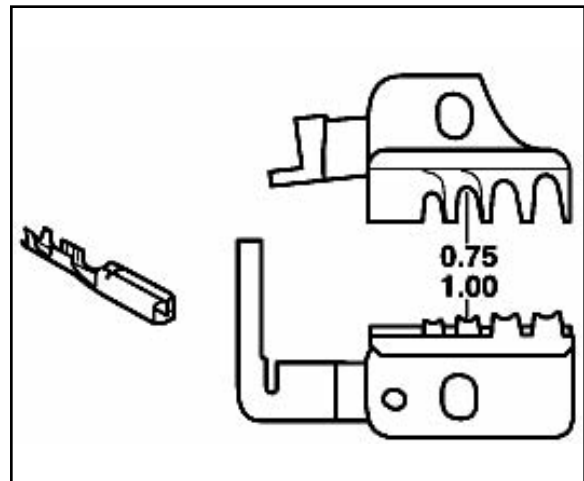
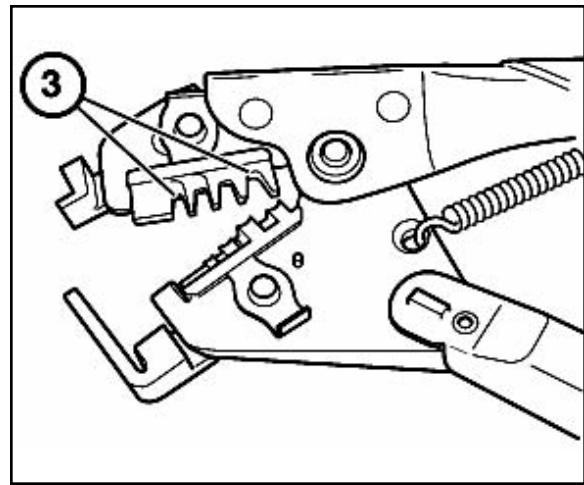

Squeeze the tool handle slightly to set the tool in the first ratchet latch position. This will hold the connector in the tool without closing the crimp (6).

Insert the stripped wire into the receiving end of the crimper tool making sure the wire is inserted far enough to ensure that only the wire insulation will be inside the insulation support barrel (7).

Properly crimped connectors exhibit the following characteristics:

- The insulation support barrel will be crimped consistently and snug against the insulation. The insulation will not be crushed (8).
- A bellmouth crimp will be visible at the wire end of the of the wire barrel (9).
- Wire strands will be visible at the contact end of the wire barrel (10).
- Insulation end will be visible in this area (11) (Fig. 27/1).

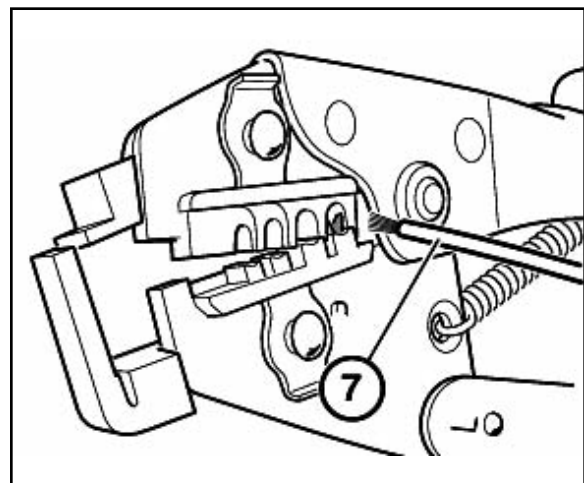
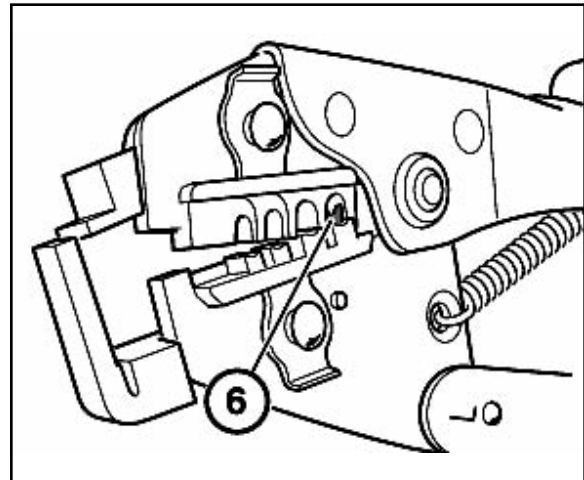

The following are examples of unacceptable crimps: (Fig. 27/2)

- Excessive or no wire strands at the contact end of the wire barrel (10).
- Excessive or no insulation end in the acceptable area (11).

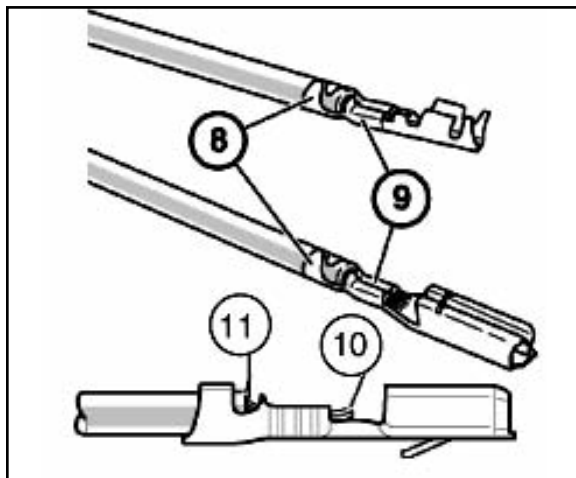

**Fig. 27/1**

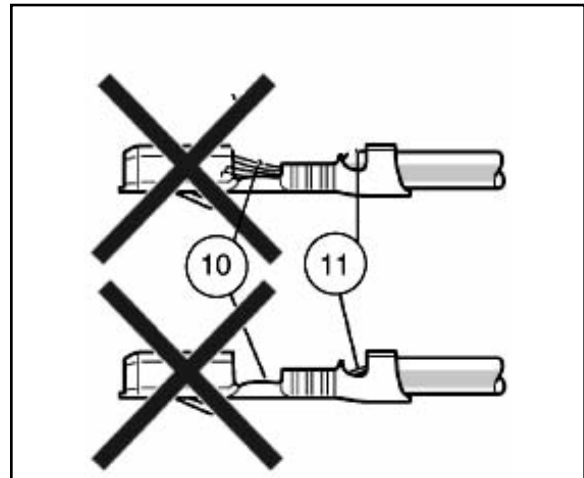

**Fig. 27/2**

## Prepackaged Wiring Repair Sets

Included with the Electrical Repair Kit IV are a variety of wiring repair sets. These sets contain various pre-crimped wiring connectors on assorted gauge wire lengths for simple splice connection repair into a wiring harness.

The repair kits also contain:

1. Various gauge lengths of wire with pre-crimped connectors.
2. In-line splice connectors.
3. Heat shrink tubing.

When used correctly the in-line splice connectors provide a BMW factory approved wire crimp. Use the correct size nest in the crimper tool and connect one side of the in-line crimp with the wire.

Slide a piece of heat shrink tubing on the wire and crimp the other side of the in-line connector.

Use a heat gun to shrink the tube around the splice connector to provide a moisture resistant seal.

Part numbers for the wire sets or any component of all four electrical repair kits can be re-ordered from:

- The P/N reference card inside each repair kit.
- Special tools microfiche.
- The Electrical Repair Kit 1-4 component catalog (**SD 92-036**).

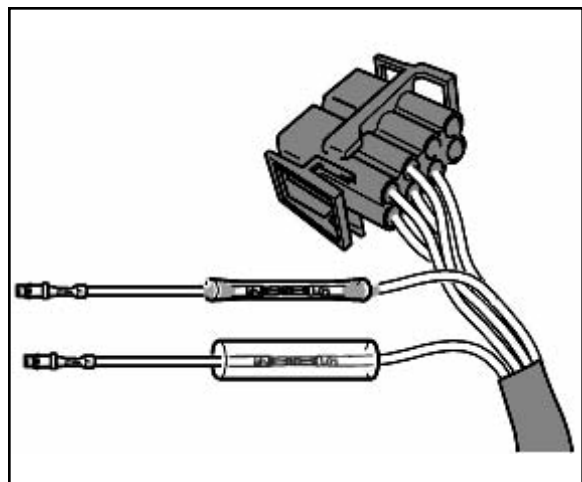
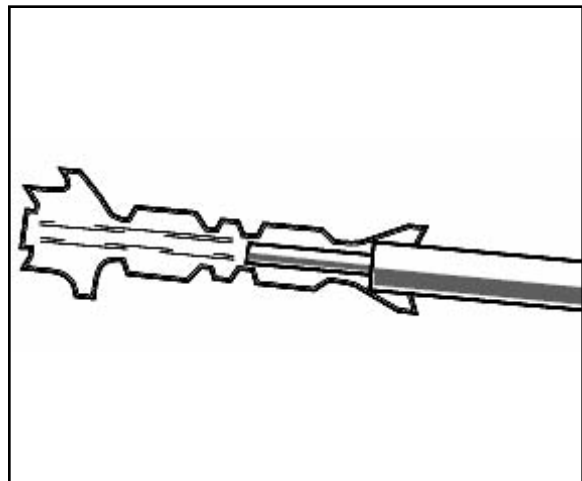
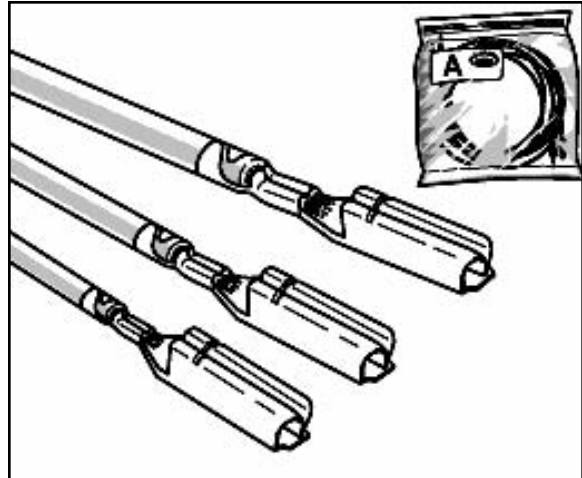

As new connectors are developed for new vehicles, the repair kits will be announced by Service Information bulletins and sent to dealerships via automatic tools shipment.

## Soldering Connections

In the event that a wiring connection must be soldered in a vehicle's electrical system, there are certain procedures which must be followed. Improper soldering will result in poor electrical connections or damage to electrical components.

**SAFETY:** Adhere to the following basic guidelines when preparing to solder.

- **Safety glasses must be worn.**
- **Disconnect vehicle battery.**
- **Cover vehicle trim surfaces.**
- **Exercise your common sense.**
- **Provide adequate ventilation, it's the best safety precaution!**

### Soldering Preparation and Procedure

- The wire insulation must be stripped to expose an adequate amount of bare wire (not too little-not to much.)
- The wires and or connectors must be clean and free of grease, dirt, wax, etc.
- A thin coating of rosin core flux must be applied to the soldering connection.
- Have enough 60/40 (tin/lead) general electrical solder on hand prior to starting.
- If heat transfer to a heat sensitive component is possible use "heat sinks".
- Use a soldering gun tip that is the right size for the job. Do not use an overly large tip which could melt wire insulation and block your view of what is being soldered.
- The soldering tip must be "tinned". This means to keep a thin layer of solder on the tip at all times during soldering. This will transfer the heat quickly and allow the solder to flow easily into the joint being soldered.
- Preheat the wires or connector. Introduce the solder into the joint not the soldering tip.
- When the solder starts to flow allow it to infiltrate the joint only for a moment. Almost simultaneously, pull the tip off of the joint to prevent overheating.
- A properly soldered joint will be smooth, shiny, and even surfaced.

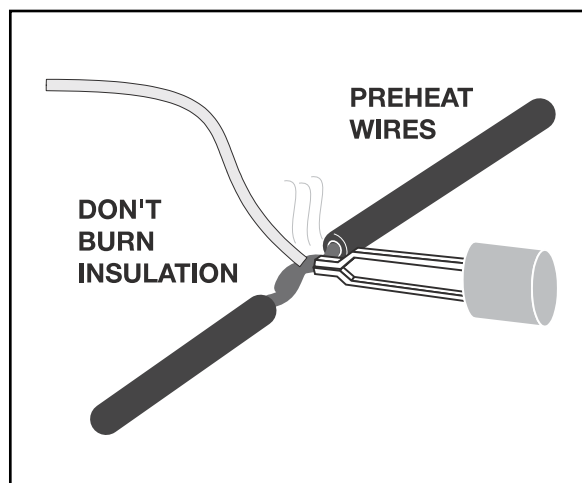
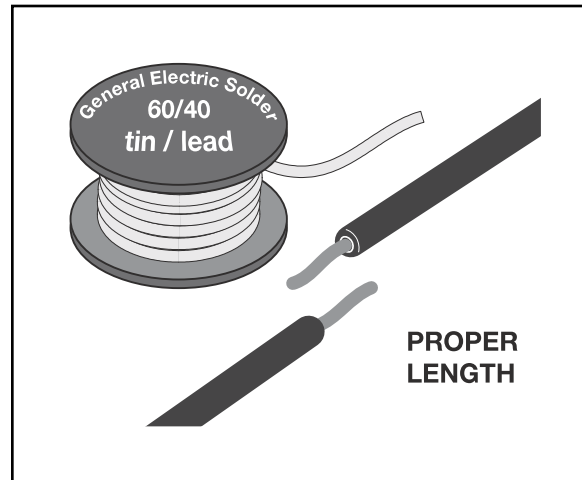

# Break Out Boxes and V Cables, Tester and Adapter Sets

## Breakout Boxes and “V” Cables

**Breakout Boxes** are used to:

- Provide a convenient “tap” into an electrical circuit.
- Minimize the possibility of damage to control unit connections and wire harnesses during diagnosis of electrical/electronic systems.
- Ensure solid meter connections for proper diagnosis, this in turn will help the technician to be more organized and efficient.
- Provide easier access to circuits for testing with equipment such as, multimeter, DISplus tester or other diagnostic tools.

**CAUTION:** Breakout box cable connections are universal in order to fit the varying coded connectors found in the vehicles. Always confirm that you are connecting the correct control module into the system harness that is on the other side of the breakout box. System damage will occur if it is not the correct system.

**Example:** DME and EGS/AGS control modules both utilize an 88 or 134 pin control module. These control modules reside in the same E-Box on most vehicles. The control modules are coded to prevent unintentional cross connecting at the vehicle harness. But, this connector coding is not present on the 88 or 134 pin breakout box(s). **Result: A DME control module could be connected to a transmission control system. Damage will result!**

Several different types of breakout boxes are available depending on the particular system being diagnosed.

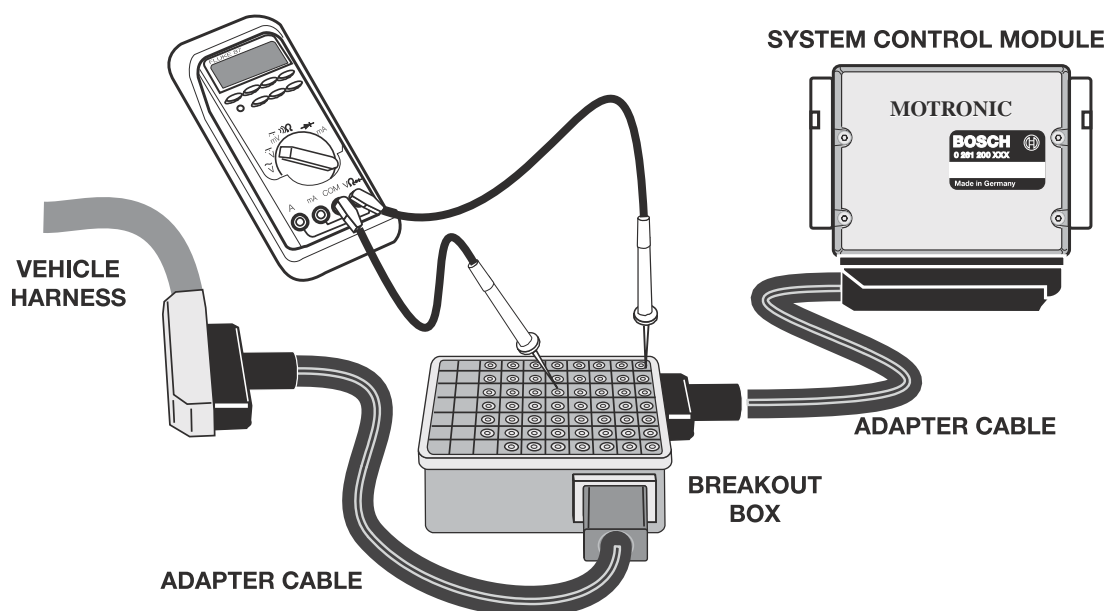



### 55 pin Breakout Box P/N 81 12 9 425 091

Used with control modules that have single multi-pin plugs from 25 to 55 pins.

- L-jetronic
- ABS
- Motronic
- EGS

Adapter cables are required.

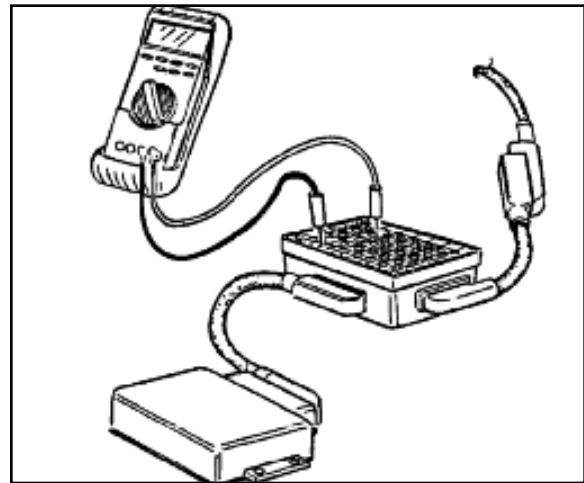

### 83 Pin Breakout Box (Red Face) P/N 90 88 6 614 420

When used with ABS/ASC 5 system, no adapter cables are required. See SIB 04 10 95 about an adapter harness for use with the Teves Mark IV G ABS system of the E36.

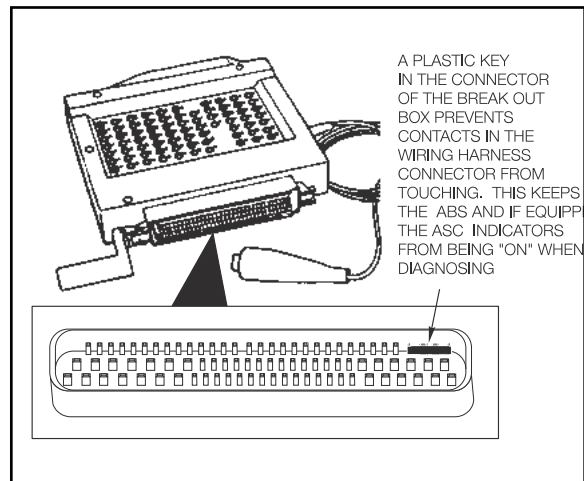

### 88 Pin Breakout Box (Green Face) P/N 88 88 6 614 410

Used with control units that have up to 88 pins;

- DME
- EGS/AGS
- ZAE/MRS
- LCM

No adapter cables are required when connected to a DME or EGS/AGS control module. See SIB's **04 26 96** and **04 15 96** about adapter harnesses for ZAE/MRS and LCM systems.

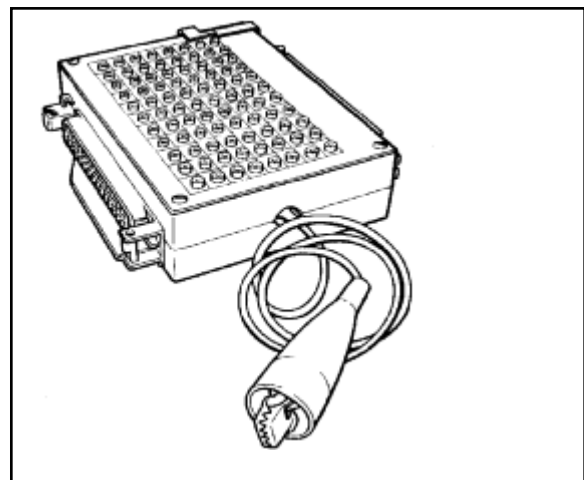

**134 Pin SKE Control Module  
Breakout Box Set  
P/N 90 88 6 121 300**

The 134 pin modular connector DME and AGS control modules use a combination of breakout boxes for troubleshooting. The part number above provides three breakout boxes and five adapter harnesses. The two outside edge connectors use the familiar 26 pin breakout boxes. The three inside connectors use the boxes from the ordered set.

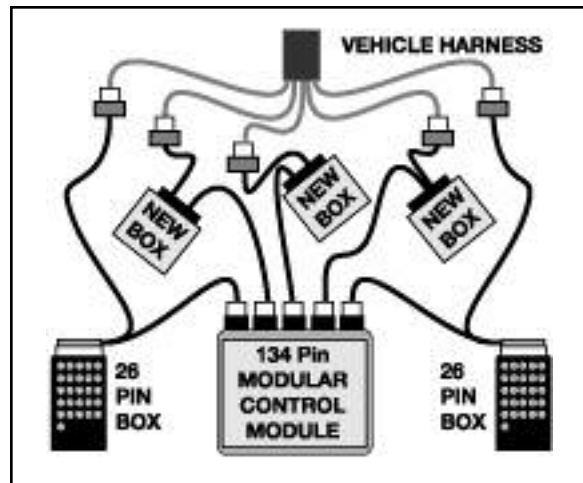

**26 Pin Breakout Box  
P/N 88 88 6 611 459**

Used with system or peripheral control module that have up to 26 pins. This breakout box is used in conjunction with adapter cables called "V" Cables. There are many different types of "V" cables for the various connectors found on the vehicles.

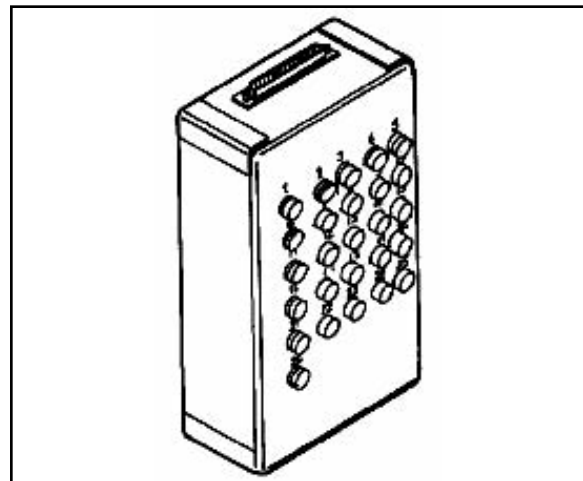

**60 Pin Breakout Box  
P/N 90 88 6 614 390**

Used for connecting all adapter leads with 27 pin to 60 pin plug connections.

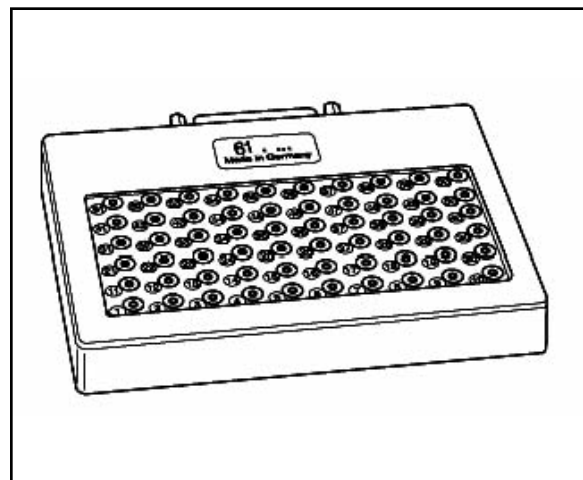

---

## “V” Cables

“V” cables are available in different versions depending on the system being diagnosed. Always refer to the most recent Service information for the required special tools.

“V” cables are only used with the 26 pin breakout box to access input and output signals of peripheral modules and systems.

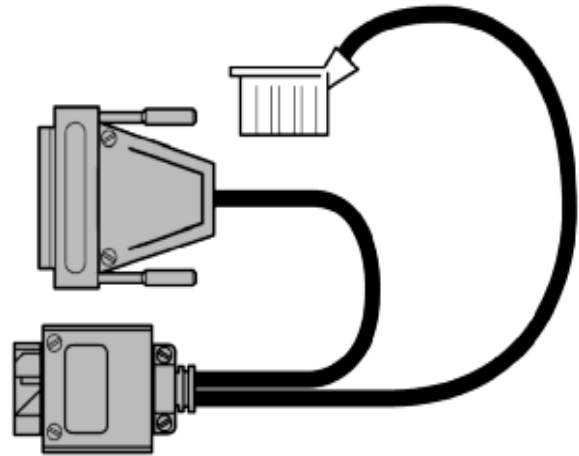

- The appropriate cable is distinguished by the color of the connector end.
- The color will match the particular modules connector color. Unless the color matches, the cable will not fit the connector on the module being tested.
- Each colored “V” cable has a series of alignment tabs that will only fit it’s particular module or system.

“V” cables with ELO connectors are also being used with the 26 pin breakout box. These cables are unique in that they have a locking arm on the component side of the cable. They are light green in color, and the number of pins will vary depending on the system being tested.

“V” harness adapters were introduced with the E38. These also have light green ELO connectors on the component side, but they do not require a breakout box. There is a black plug on one side with same number of pins as the component being tested. The plug has numbers stamped on it’s side that corresponds with the pins on that particular component. You access the signals by plugging the test equipment directly into those pin numbers.

As new systems and components are being introduced, new breakout boxes and cables will also be introduced.

Always remember to refer to the most recent service information in TIS or Service Information Bulletins for the latest diagnostic tools and procedures.

## Tester and Adapter Set for Relays

The Relay Adapter provides a platform to test a relay while allowing the relay to remain active in a circuit.

The adapters included enable different pin configurations of relays to be tested using a single tester.

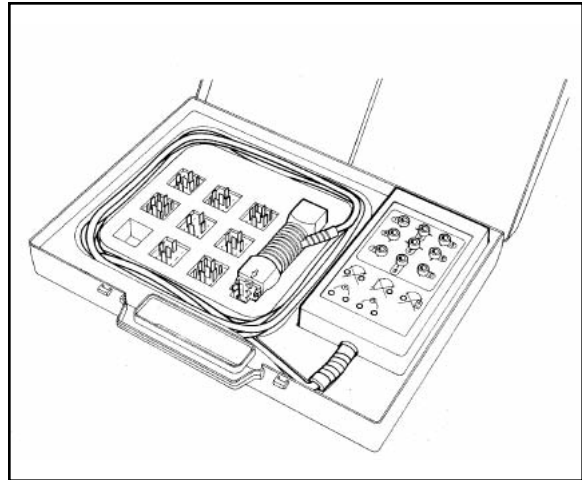

Remove relay and compare plug in adapter with plug pattern on relay. Choose correct adapter (Fig. 33/1).

Fit adapter to Measuring bridge, noting the marker arrows (A). Fit the relay to the measuring bridge (Fig. 33/2).

Plug the assemble measuring bridge into the socket of the relay to be checked. Test using a multimeter. See the circuit diagram, testing instructions and repair manual for subsequent procedure (Fig. 33/3).

**Fig. 33/1**

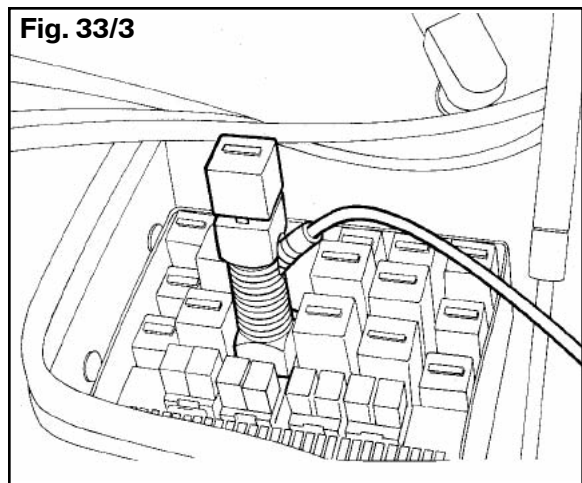
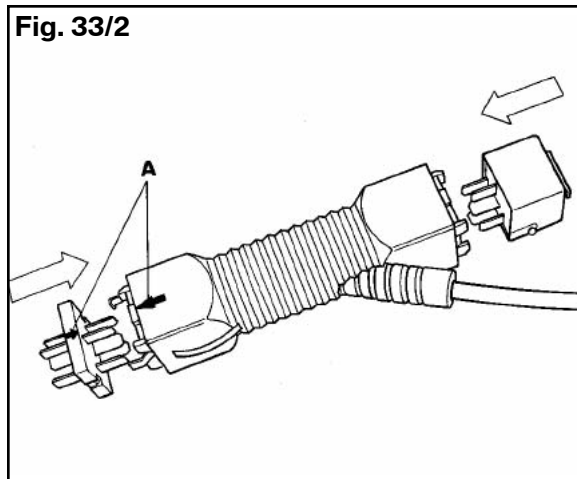
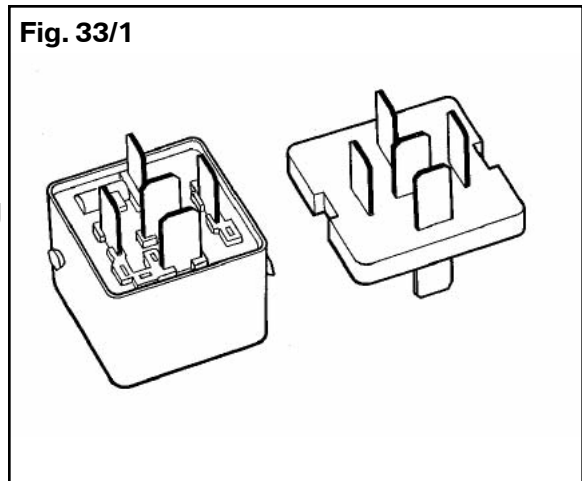

## Examples of V cables

Part number	Description	Chassis	Use
61 1 260	30 Pin V cable	E46	Wiring door harness
61 1 270	24 Pin V Cable	E46	Connection on seat plug
61 1 460	Set of 8 cables	E32,36,38	Door harness and others
61 1 480	Set of 7 cables	E30,32,34	Various electrical systems
61 1 490	Set of 2 cables	E34	Engine wiring harness
61 2 050	2 Pin V cable (JPT)	E31,32,34	Servotronic
61 2 070	Set of 3 cables	E36,38,46,	Electrical front seat
61 3 030	V cable	E38	DSC 3 control module
61 3 150	54 Pin adapter	E46	Light module
61 3 190	Test Leads	E38,39	EWS
61 3 210	5 Pin V cable	E46	Seat heating
61 3 220	8 Pin V cable	E46	Power window and interior light
61 3 240	8 Pin V cable	E46	Door locks
61 4 350	V cable	E38,39,46	Center console switch
61 4 450	20 Pin V cable	E30,31,36	LKM and EM convertible top
61 4 460	Set of 4 26 pin cables	E31,34,36	Various electrical systems
61 6 020	Set of 6 cables	E38	Various electrical systems
61 6 030	Set of 5 cables	E38	Various electrical systems
61 6 040	Set of 5 cables	E38	Various electrical systems
61 6 050	6 Pin V cable	E39,46	Various electrical systems

### Important Notes Concerning Airbag Repairs:

Only repair those cables which show visible signs of damage. If there is visible damage, make sure that only one cable repair is present after repairing. If no visible damage can be identified, the entire cable must be replaced. When carrying out repairs to the airbag wiring harness use only those parts specified in the EPC as "Airbag Repair Cable".

#### Airbag Repairs

Always refer to the latest SIB for information pertaining to the latest Airbag repair procedures.

**SIB 61 02 00**

#### Plug Adapter Relay Tester

Part Number	Use
61 3 013	Crash Sensor
61 3 014	Hazard Warning System
61 3 015	Hazard Warning System C2
61 3 017	Changeover Relay
61 3 018	N/O (Normally Open) Relay
61 3 019	Rear Window Heater
61 3 021	Windscreen Heater
61 3 016	ABS

---

NOTES

PAGE